

**HSD-RP01**



HSD-RP01 is a Roll / Pitch sensor with CAN-BUS connection. It uses a temperature compensated accelerometric angle sensor, with high accuracy and repeatability. The sensor is equipped with a built in microprocessor that grants compensation and connectivity. An armoured body is ideal for rough hydraulic application such as levelling systems for trucks. The device is fully potted of resin and it is connected through a M12 connector

**Main features**

Power Supply	8 - 32 VDC
Operating temperature	-40°C / +70 °C
Ingress Protection	IP66
Connector	M12x1 5poles male A
Sensing Range	+/- 60° on X and Y
Accuracy	0,3°
Thermal Drift	+/- 0,001 deg/°C
Vibration resistance	EN60068-2-6
EMC Standard	EN61000-6-2; -4
MTTFd	220Y

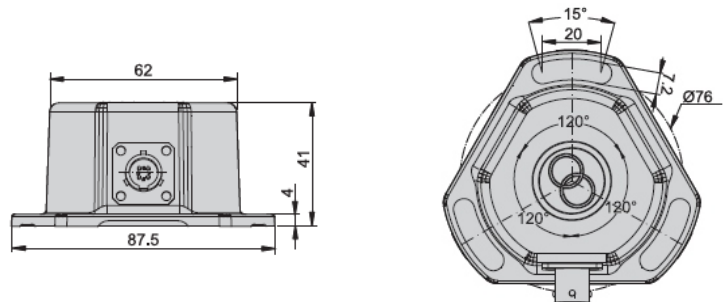

**PinOut                      Function**

1	NC
2	+VB
3	-VB
4	CAN H
5	CAN L