

SMART POWER UNIT

**Digital Hydraulic Power Pack
with on Board Electronic**

Safety Architecture up to SIL2

IEC 61131-3 Compliant

XDRAULICS



What is Mechatronics

Hydronit has developed the world first Smart Power Unit.

A Smart Power Unit is a combination of a Compact Hydraulic Power Pack, with a Powerful electronic controller, all driven by a custom Software. This combination of electronic, hydraulic, sensors and software is called Mechatronics.

Historically, one of the most pervasive Mechatronic system that everyone knows is the ABS system, present in all cars, which was the first to combine conventional hydraulics to an electronic controlling unit:

The ABS is connected to the vehicle through a set of sensors:

- pick-up sensor, reading speed of each wheel
- steering wheel angle sensor
- brake pressure sensor
- inertial platform (for ESP function)

Unlike ABS, which is a single task device, Hydronit's SPU is programmable through a well known IDE: CoDeSys, a programming environment which offers multiple coding languages for any application. The CoDeSys IDE is free for users.

Unlike ABS, which has a rigid hydraulic scheme, Hydronit's SPU can be equipped with a wide and modular range of hydraulic components as per PPC Compact Power Packs catalogue. Additional Hydraulic components are available as NG6 (Cetop 3) proportional valves and stackable Load Sensing valves (proportional and on-off)

In order to enhance the possibilities offered by a programmable hydraulic power pack, the SPU is equipped with CAN-BUS lines, which can be connected to:

- HPC: Hydraulic Process Controllers
- HVI: Displays, Control Panels
- HMI: Keyboards, Switches, Joystick
- HSD: Sensors

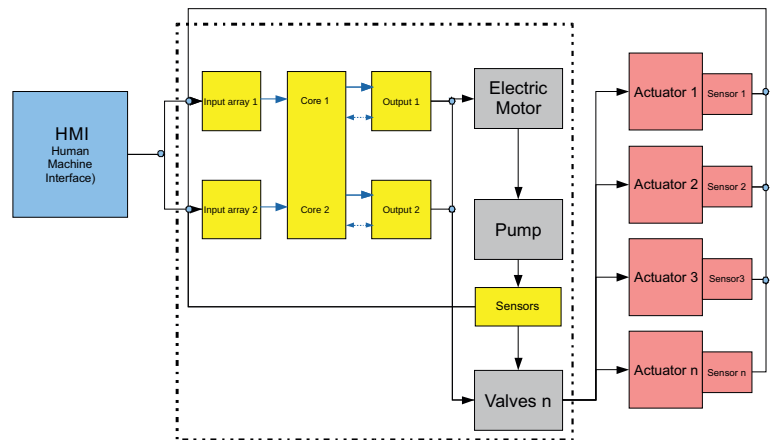
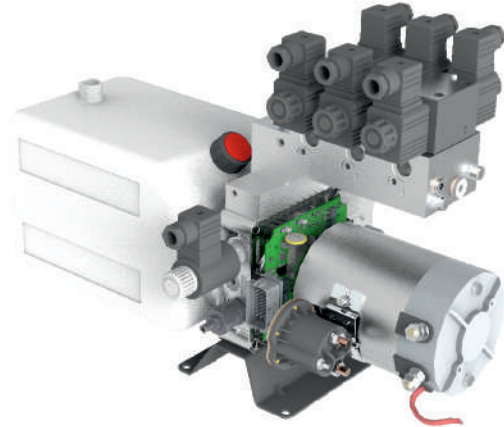

Smart Power Unit logic architecture: a SIL2 electronic architecture ready to drive redundant hydraulic circuits

Q & A

How to customise SPU?

SPU is a programmable device, that allows free programming. The programming environment is CoDeSys, an IDE based on the international standard IEC-61131. It allows SPU programming using multiple language methods such as Function Blocks (FDB), Structured Text (ST), Ladder (LD) and others.

What is the cost of CoDeSys programming environment?

CoDeSys IDE is free for SPU customers.

What about graphics of displays and keyboard?

Graphic Displays are customised by Hydronit as per customer specifications. Keyboards are customised through the use of plastic inserts available with more than 200 symbols. On request special symbols are available.

Does Hydronit provides cable harnesses?

Connectors or simple cable harnesses are available as a standard offer. Complex machine harnesses are available on request as per customer specifications.

Hydronit Smart Power Unit

The **SPU** is the second generation of **Programmable Digital Hydraulic Power Pack** available on the market.

The core of the Smart Power Unit is the **HPC (Hydraulic Process Controller)**: a Mechatronic Module which integrates Sensors, Electronics and Hydraulics in a single device. Programmable with **Codesys™** IEC61131-3 automation software.

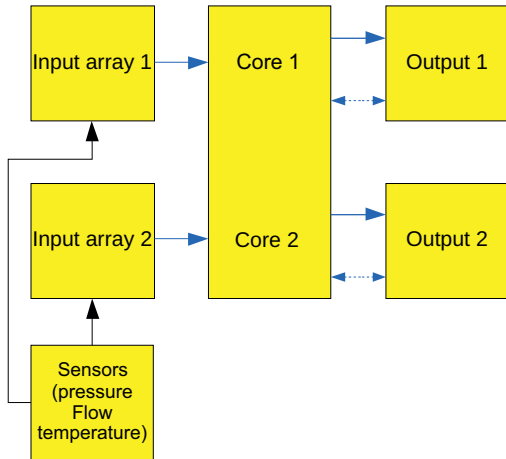
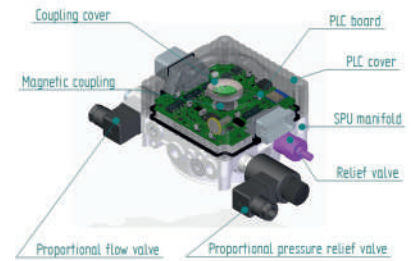

Features

The core of the Smart Power Unit is the **HPC (Hydraulic Process Controller)**: a programmable controller with **SAFETY Architecture**. It integrates I/O, sensors, double cores processor to enable SAFETY features, power Output in order to directly drive solenoid operated proportional or on-off valves without the need of external relays.

The **Hydraulic Process Computer** is integrated in the power pack and available in different executions: P/Q proportional control and LS functionality.

Hydraulic Integration

The **HPC** is perfectly integrated with the standard **Hydronit Compact Pack** range since it can use same PPC components.

Hydraulic circuits are available with redundant valves in order to match mechanics to electronics and offer a SAFETY RELATED mechatronic power pack ready for **Industry 4.0** and **Smart Manufacturing**.

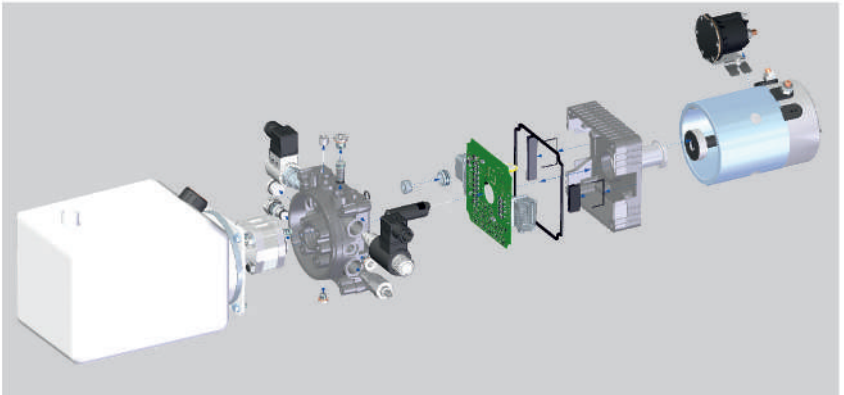

Built in Sensors

The **Hydraulic Process Computer** integrates fluid sensors: one ceramic **Pressure sensor** reading the LS line, up to 350 bar.

An oil temperature sensor completes the fluid monitoring.

Additional external sensors can be need through the I/O lines and two CAN BUS networks.

Sensors are embedded in the mechanic body and are available as a variable in the software programming environment.



International Awards

Hydronit directly competing against European most innovative companies, has been awarded with multiple **Seals of Excellence** by the European Commission **during Horizon 2020 Framework Programme for Research and Innovation**.

In July 2017 it has been granted by EU Commission as project 779020

The **Smart Power Unit** is patented.

Typical Application

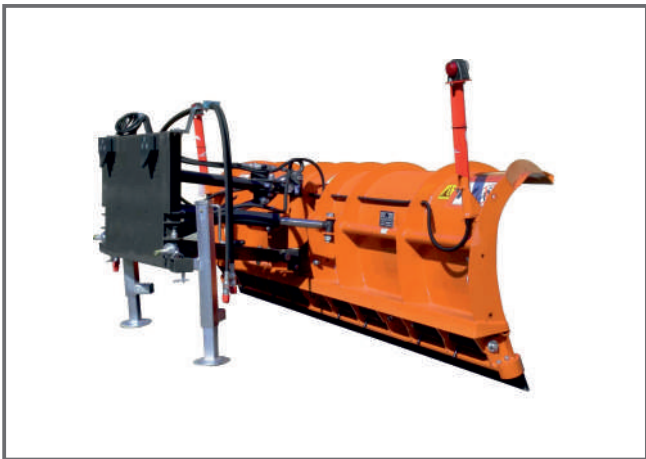
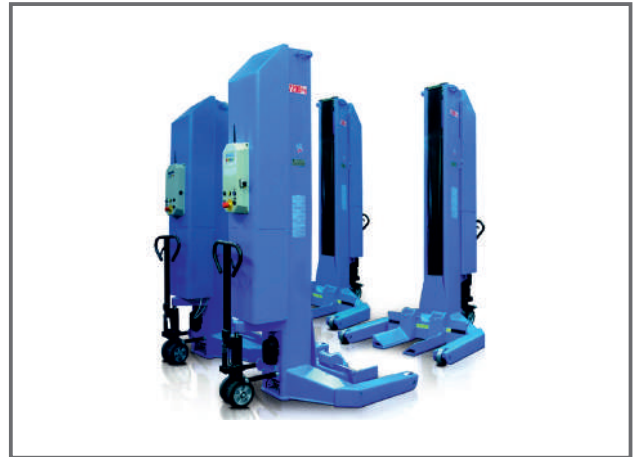

Typical Technical Application

Example Forklift Hydraulic Scheme

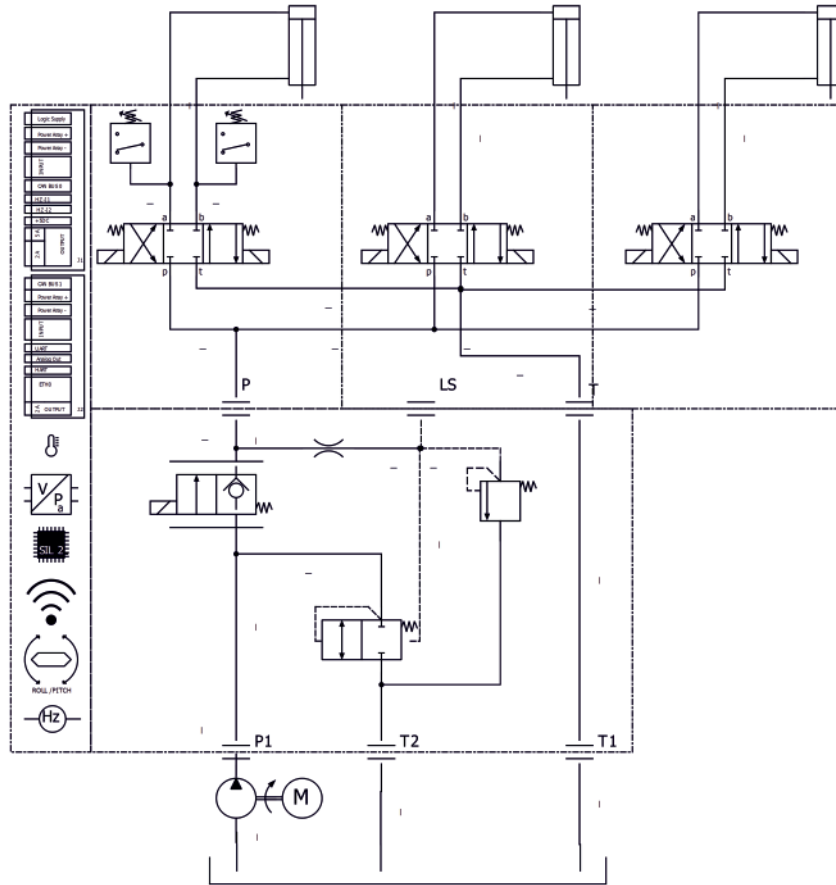

Example Snowplow Hydraulic Scheme

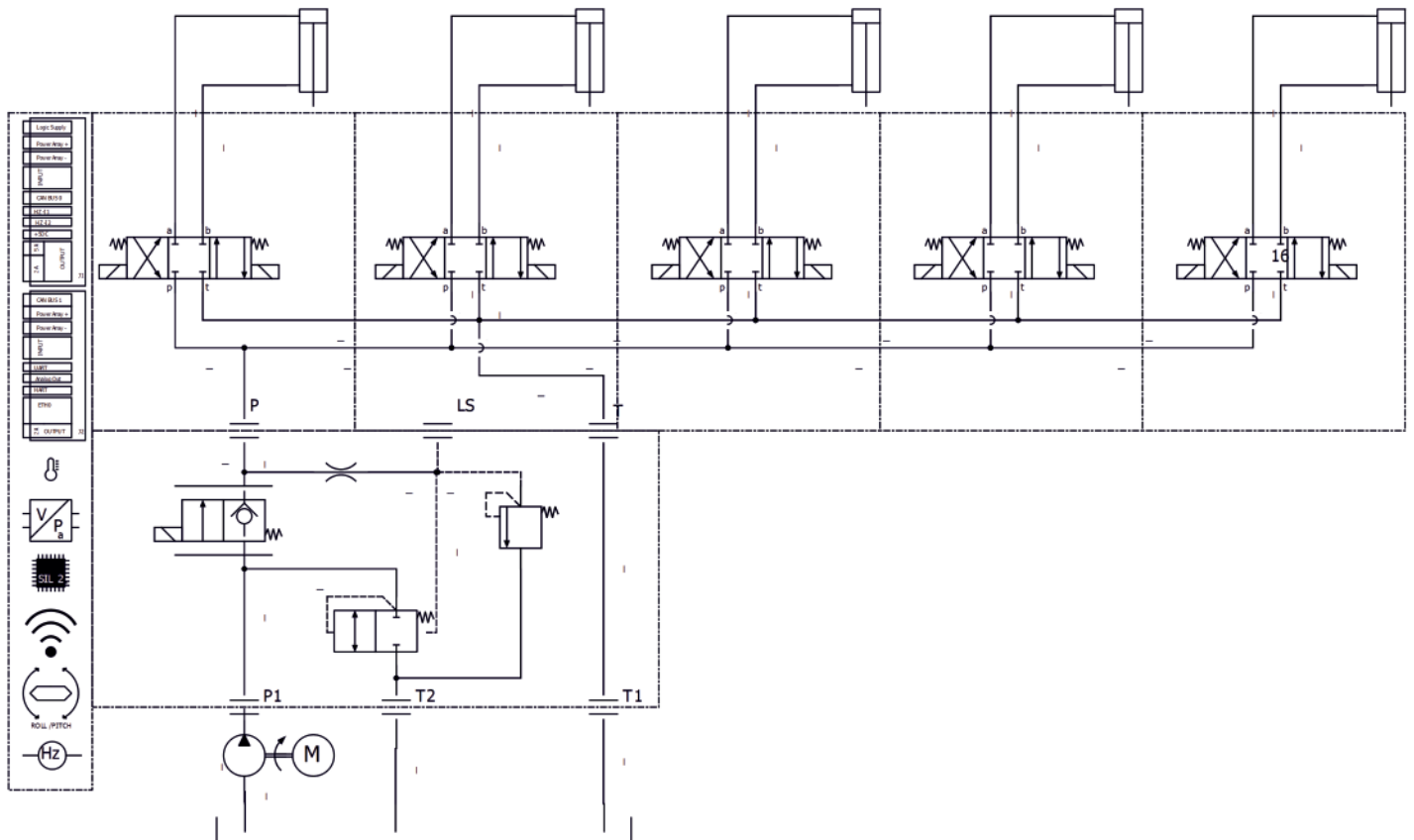

Typical Technical Application

Example Undercarriage/Towerlight Hydraulic Scheme

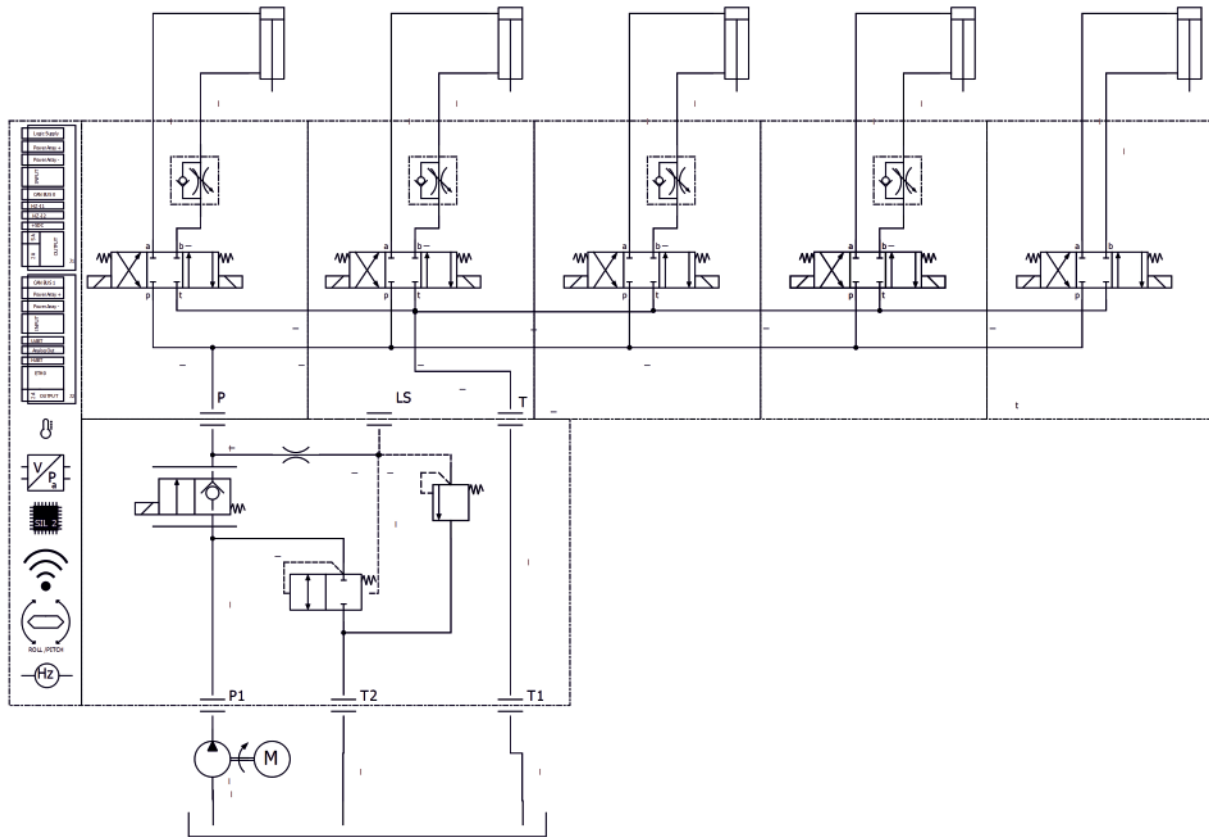

Example Twin scissor lift Hydraulic Scheme

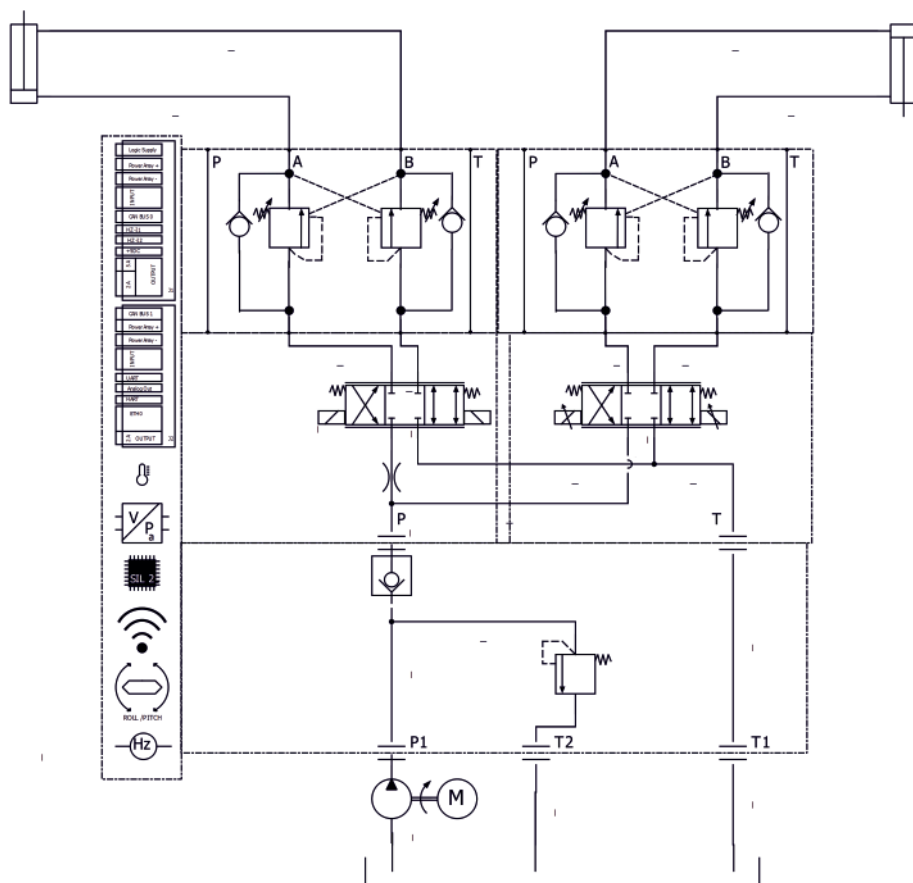

Typical Technical Application

Example Mobile column lift Hydraulic Scheme

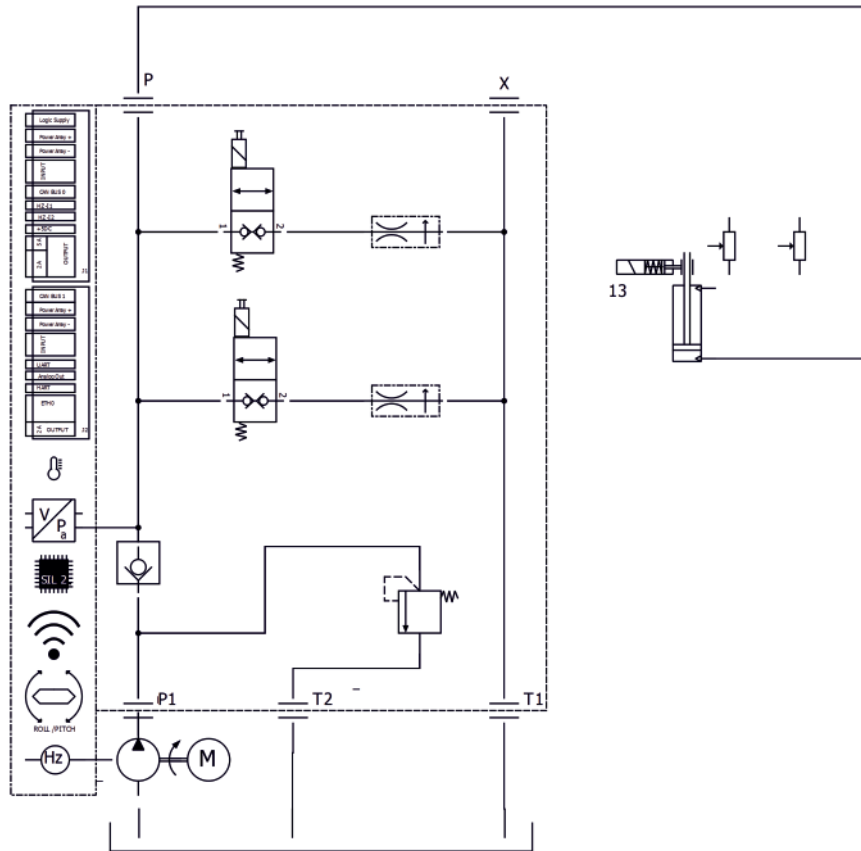

Example Tyre Changer Hydraulic Scheme

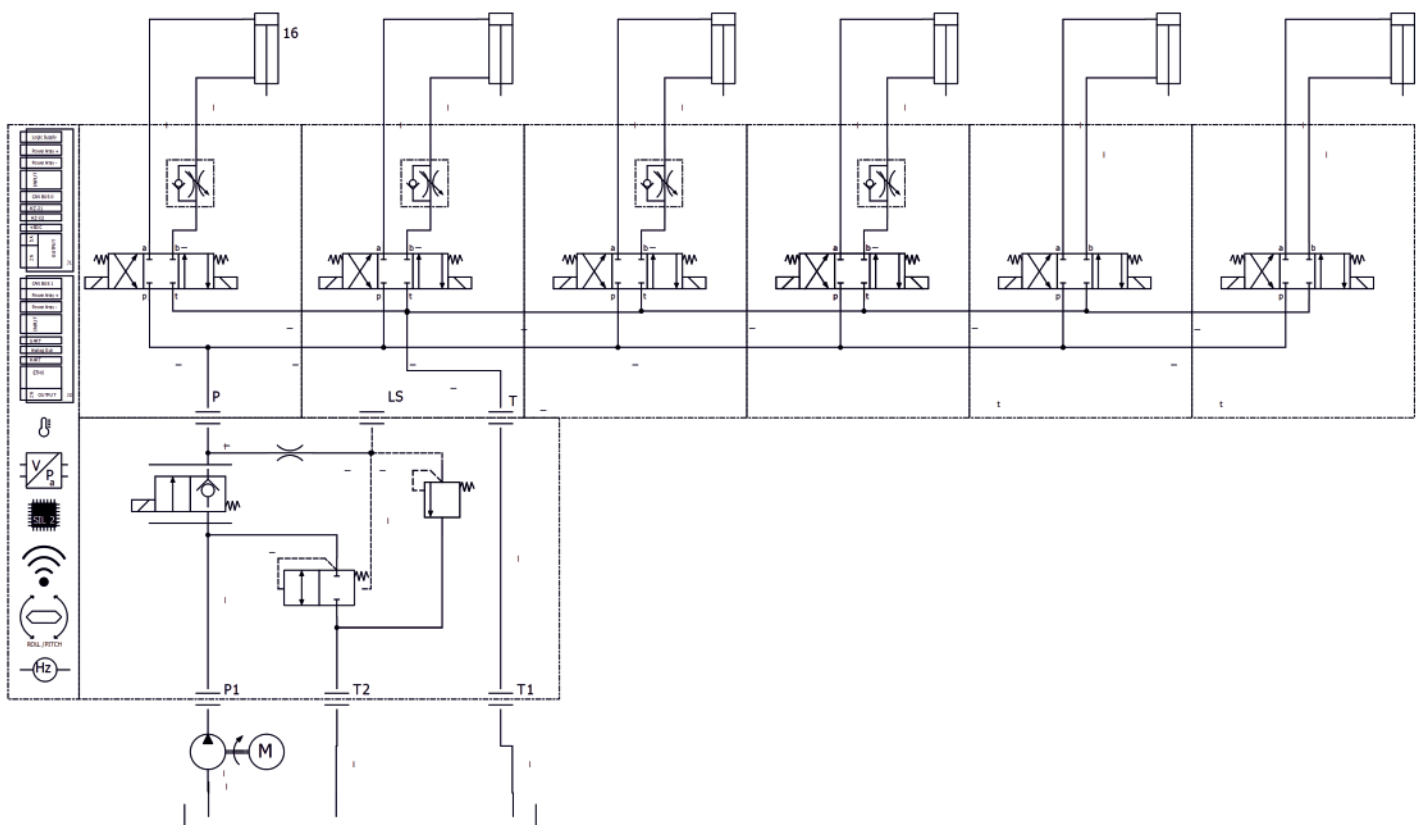

Digital Controller Main Features

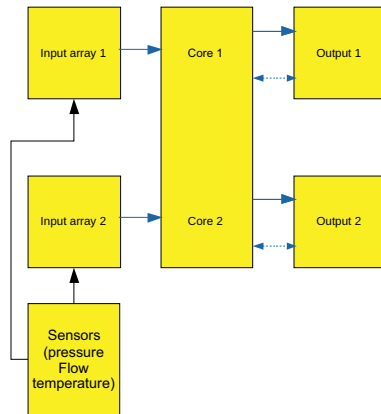

Technical data:

Voltage range:	9...60V DC
Current consumption:	<= 200mA
Operating temp. range:	-40 ... +85°C
Storage temp. range:	-40 ... +85°C
Weight:	< 0,5 Kg

IOs:

2 x 6 (12) of Digital/Analogue inputs:
0-25 mA, 0-5 V, 0-30 V, ON-OFF

3 x 4 (12) of Digital/PWM outputs 2A:
close current loop with ON/OFF status feedback input

2 x 1 (2) of Digital outputs 5A:
with ON/OFF status feedback input

2 x CAN Bus ISO 11898 24 V DC

1 x Ethernet ISO/IEC/IEEE 8802

Mechanical shocks and vibration resistance

Sinusoidal vibration: 5...500 Hz,
7.5 mm, 5g, 5 cycles,
variation 1 octave/min (EN 60068-2-27);

Shock: 25g, 6 ms,
4000 shock for every direction and axis,
within the working temperature range;

Free fall (EN 60068-2-32 1 m unit boxed);
Tilt fall (EN 60068-2-31 100 mm)

EMC compatibility

EN13309 (Construction Machinery)
EN61000-6-2 (Immunity for Industrial Environments)
EN61000-6-4 (Emission for Industrial Environments)

Further electrical protection

Inversion of polarity protection
Over voltage protection (SURGE)
Load Dump Protection

General rules compliance

European Standard:
RAEE 2002/96/EC
RoHS 2002/96/E

The Digital Architecture of HPC consists in a processor dual core architecture, ready for safety applications up to SIL2 as per IEC61508 (it requires specific software and certifications, available for quantities). The software, developed with CoDeSys, is uploaded in both cores and in case of incongruency, the hardware Watchdog stops all movements preventing dangerous unattended movements. The Electronic controller built in the HPC is equipped with two CAN BUS lines, in order to have a fast and reliable communication of the Hydraulic Power Unit with a centralised control or, eventually, with Input peripherals or sensors. HPC is able to directly drive up to 12 ON-OFF or Proportional valves with up to 2A current, with a power supply voltage of 9 to 60VDC. Two additional ON-OFF Outputs are suitable for current up to 5A.

Each Output is equipped with current sensing: this simplifies the cable harness by reducing the number of fuses and reducing installation time. The logic supply circuit is independent from the power circuit in order to easily connect emergency circuit breaker while keeping on the logic: this extends data logger possibilities of the system, for a better reliability and troubleshooting capabilities.

Twelve multistandard inputs allow the connection of voltage or current sensors and ON-OFF proximities or keyboards

CPU, Memory and Software:

1 x CPU 32 bit dual core + 1 «WDO» CPU 32 bit

RM48L952 by Texas Instrument

Dual core CPUs Running in Lockstep
ARM®Cortex®-R4F 32-Bit RISC CPU
System Clock up to 220 MHz
3MB of Program Flash With ECC
256KB of RAM With ECC
64KB of Flash With ECC for Emulated EEPROM
16-Bit External Memory Interface
2 x CAN Bus Interface
1 x shared Real Time Clock

«CoDeSys» version 3.5.12 and later

Failure rate:

Analysis method: «Parts count» method over all components assuming 50% dangerous failures;

Data collection: MIL-HDBK-217F-Notice 2 and manufacturer Information;

Conditions: Normal operating conditions for environment and temperature;

Environment: Ground, Mobile;

Temperature: 40°C;

Operating Time: 10 h/d * 6 days * 52 weeks;

Component stress: Mean stress on components(not according to the circuit diagram)

Note: MTTFd relates to one of two redundant channels;

MTTFd: 48 years

Mechatronic Range

The HVI series is a range of programmable color displays, both stand-alone and CAN-BUS, programmable to show and input data from/to the SPU unit. See Section B.



Pressure, position sensors, planarity and angle sensors are available to feed-back the functional parameters to the SPU system automation. See Section C.



The HMI series is a range of peripherals such as Keyboards and Joysticks for the SPU control. See Section D.



I/O extenders are available to increase the number of Inputs and Outputs for large SPU systems. See Section A.



The on-off and proportional directional control valves, in bancable or Cetop style, complete the standard offering from Hydronit Srl. See Section E.

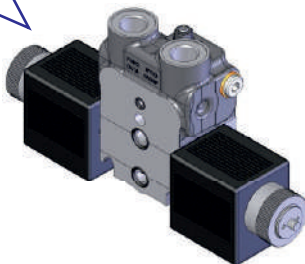

The HPC is the Smart Power Unit core system. It has built-in pressure and temperature sensors as well as an optional pump speed sensor. Pressure and flow proportional control valves set the system parameters and its electronic controller can read additional sensors and perform motion control logic. It is equipped with two CAN-BUS lines for external connectivity. See Section A.

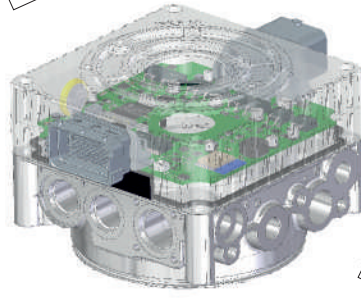

Q & A

Why Mechatronics?

Choosing Hydraulic and Electronic components, developing the necessary software, design wirings brackets and enclosures is an activity that requires a huge amount of time and energies to Machines Manufacturers. Hydronit, with SmartPowerUnit series, offers a one-stop-shop mechatronic solution in order too free time and resources to its own customers, reducing T.C.O. and TimeToMarket.

What Hydronit offers?

We offer "active" hydraulic power pack, with built in electronic and sensors ready for IOT and/or stand alone applications.

What accessories?

In addition to the Hydraulic power pack, we offer all needed peripherals for a complete automation system, such as displays, keyboards, sensors and connectors in order to grant the right compatibility level among all components, reducing time-to market a providing a complete package solution to the customer.

How do you grant the compatibility of the different devices?

Through extensive testing in different environmental conditions and applications and thanks to the in-house software development.

What if we do not want to share our know how with Hydronit?

You can program software in your facilities using our programming environments

HPC02

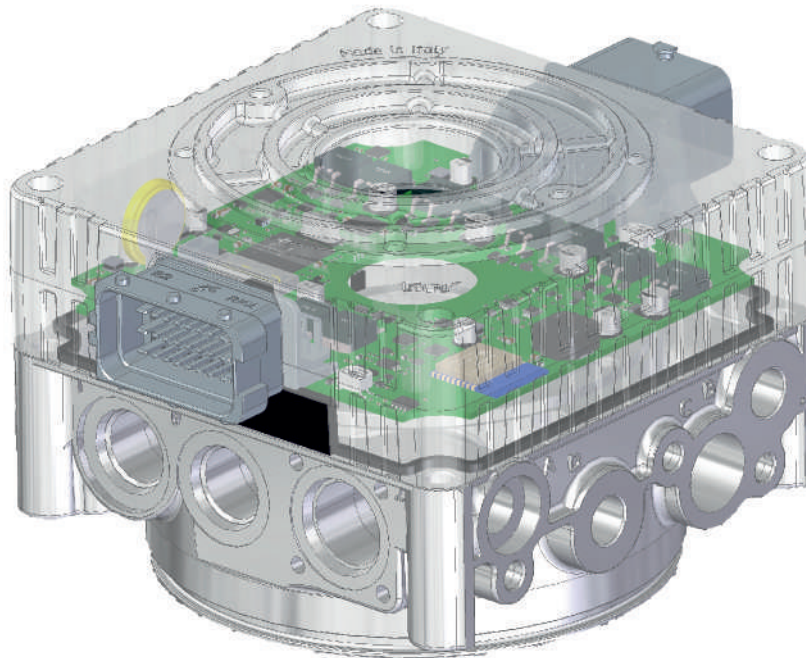

HPC02: the Hydraulic Process Controller is a Mechatronic element embedded into Hydronit power pack. It consists of:

1) die casting aluminium manifold which hosts a proportional flow regulator, pressure compensated, piloted by a proportional pressure relief valve.

2) electronic motherboard a programmable electronic controller with SIL2 processor, local Input and Output such as:

- Codesys programmable
- Software configurable Analog / Digital Input
- Software configurable PWM / Current loop / Digital Output up to 5 Amps
- Two independent CAN-BUS lines
- 3axis accelerometer
- Wifi
- Ethernet
- Built in temperature sensors
- Multi standard I/O
- Independent Logic and Power electric supply for safety configuration
- Internal WDO
- Built in motor speed sensor
- Built in delivery pressure sensor
- Hart current loop input
- Digital analog output
- Web server
- IP65 protection

3) die casting aluminium cover for protection and heat dissipate

HPC02 can be supplied with 9-60V DC and is able to output up to 35A, matching the most common and future automotive standards.

HPC02 can control DC or AC electric motors through CAN-BUS lines or through ON-OFF signals

SECTION A



HPC02Q with proportional meter-in Flow control

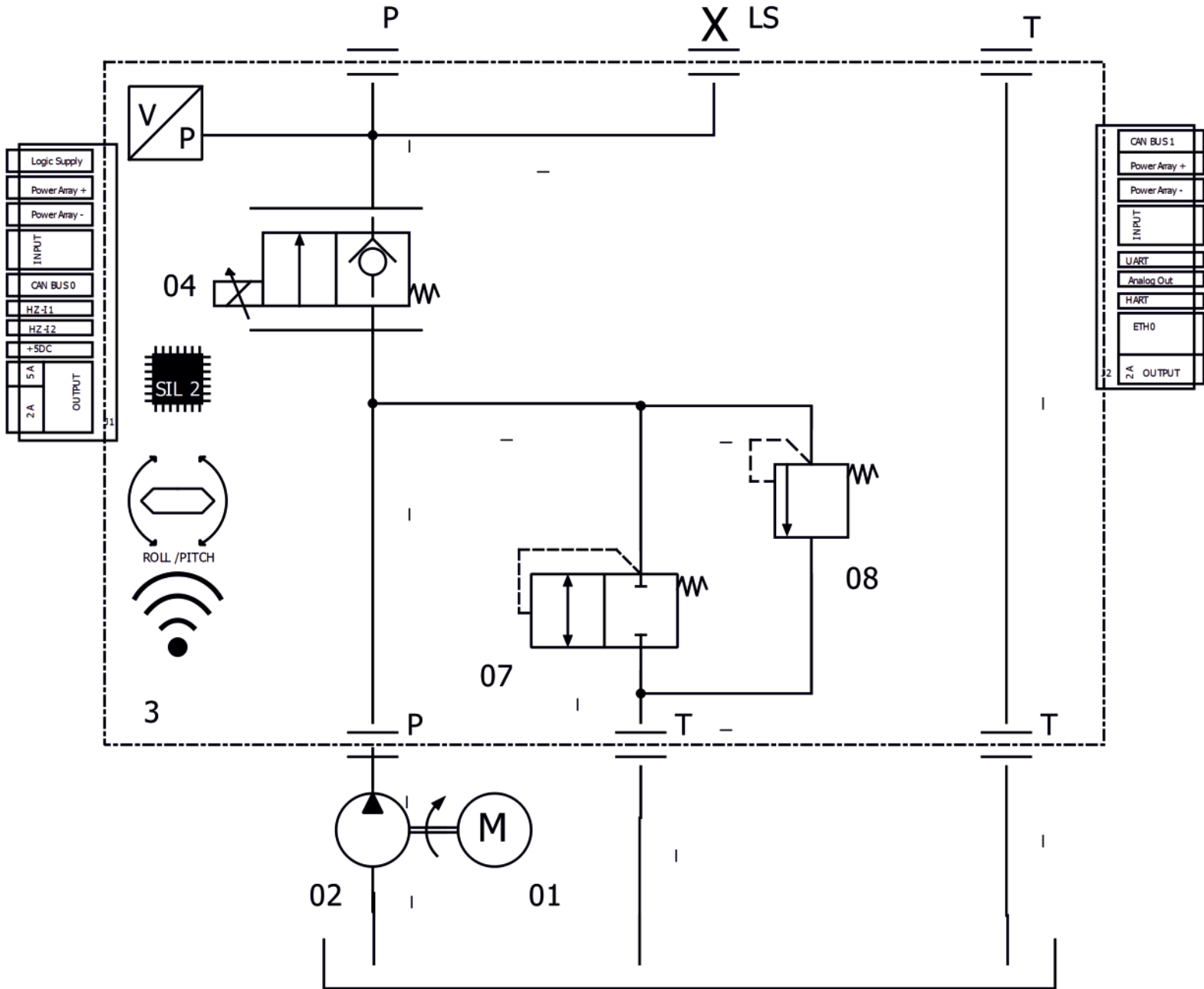

HPC02**: Hydraulic Diagrams with meter-in proportional Flow control

The Q type diagram is useful for sequential motion in automation, normally the Q manifold feeds an array of ON-OFF directional valves, regulating the common flow and the max pressure. Q system allows just sequential asynchronous movements. Typical applications are: personal lift equipment, small cranes,...

The Manifold contains a 3rd way pre-compensator which is sensing pressure across the proportional flow regulator. The proportional pressure relief valve is limiting the max pressure allowed on the system. Pressure sensors (rated for 300 bar) sense Delivery line (P) or Load Sensing Line (the other line being plugged); pressure sensor is rated for max 5 bar and senses the return line pressure. They are installed and electrically connected inside the manifold to the Logic controller. The Electronic Programmable controller drives the proportional valves according to the application software.

HPC02Q with proportional meter-in Flow control

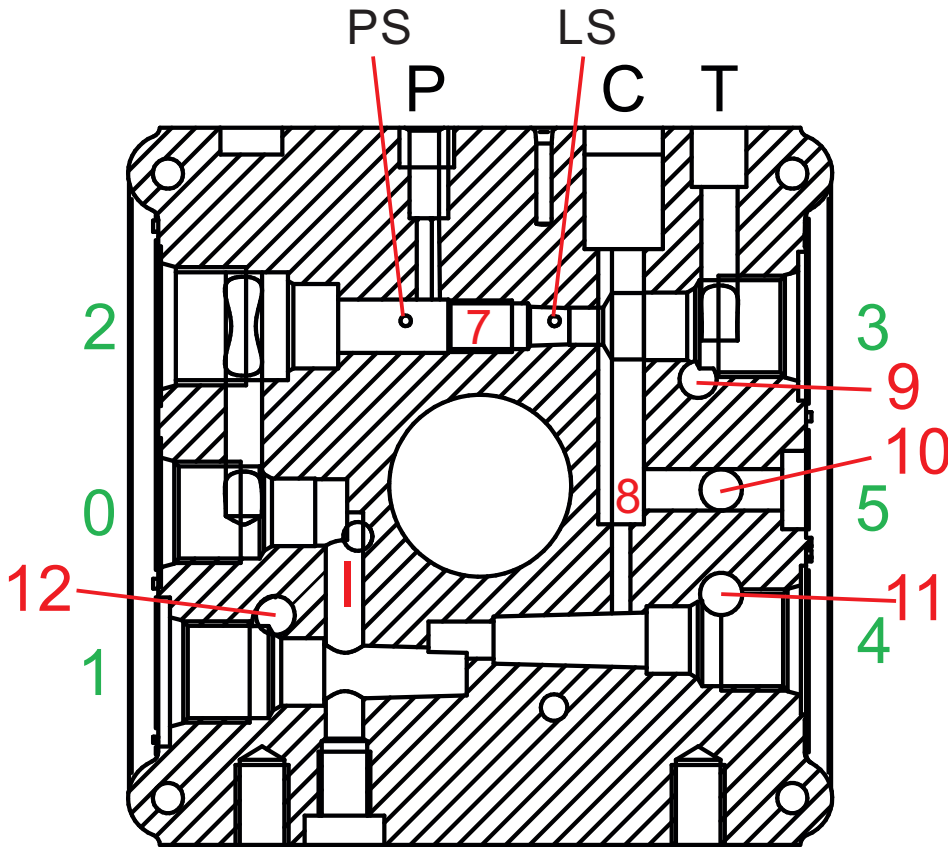

- 0) Plug
- 1) Relief valve or plug
- 2) Proportional flow valve
- 3) Plug
- 4) Relief valve or plug
- 5) Plug
- 7) Calibrated orifice
- 8) 3 way compensator
- 9) Return pipe
- 10) Return pipe
- 11) Empty or Relief valve return line
- 12) Empty or Relief valve return line
- PS) Pressure transducer
- LS) Pressure transducer on LS line
- C) Plug

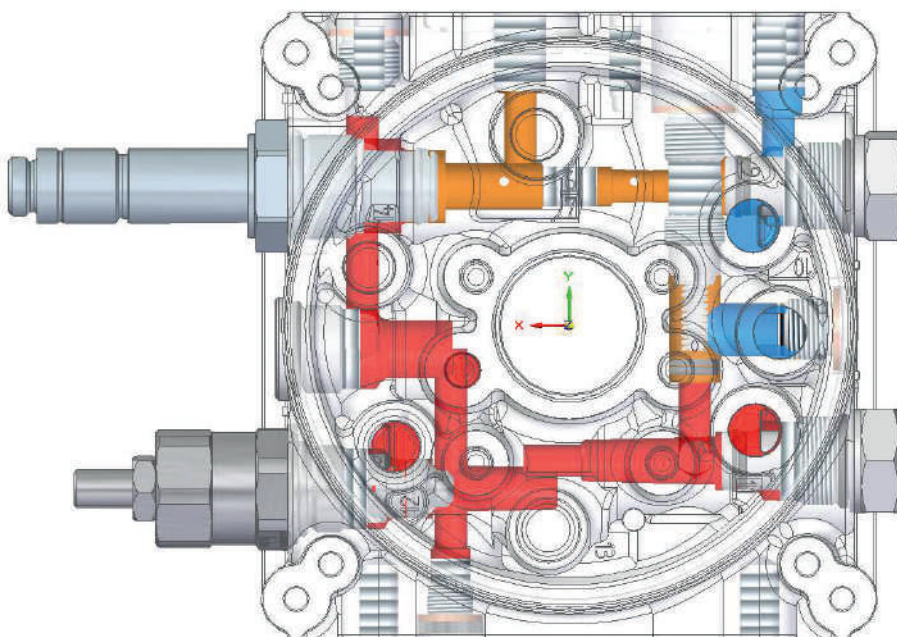

- P line
- Return line
- Reduced pressure line

SECTION A



HPC02PQ with proportional meter-in Flow and Pressure controls

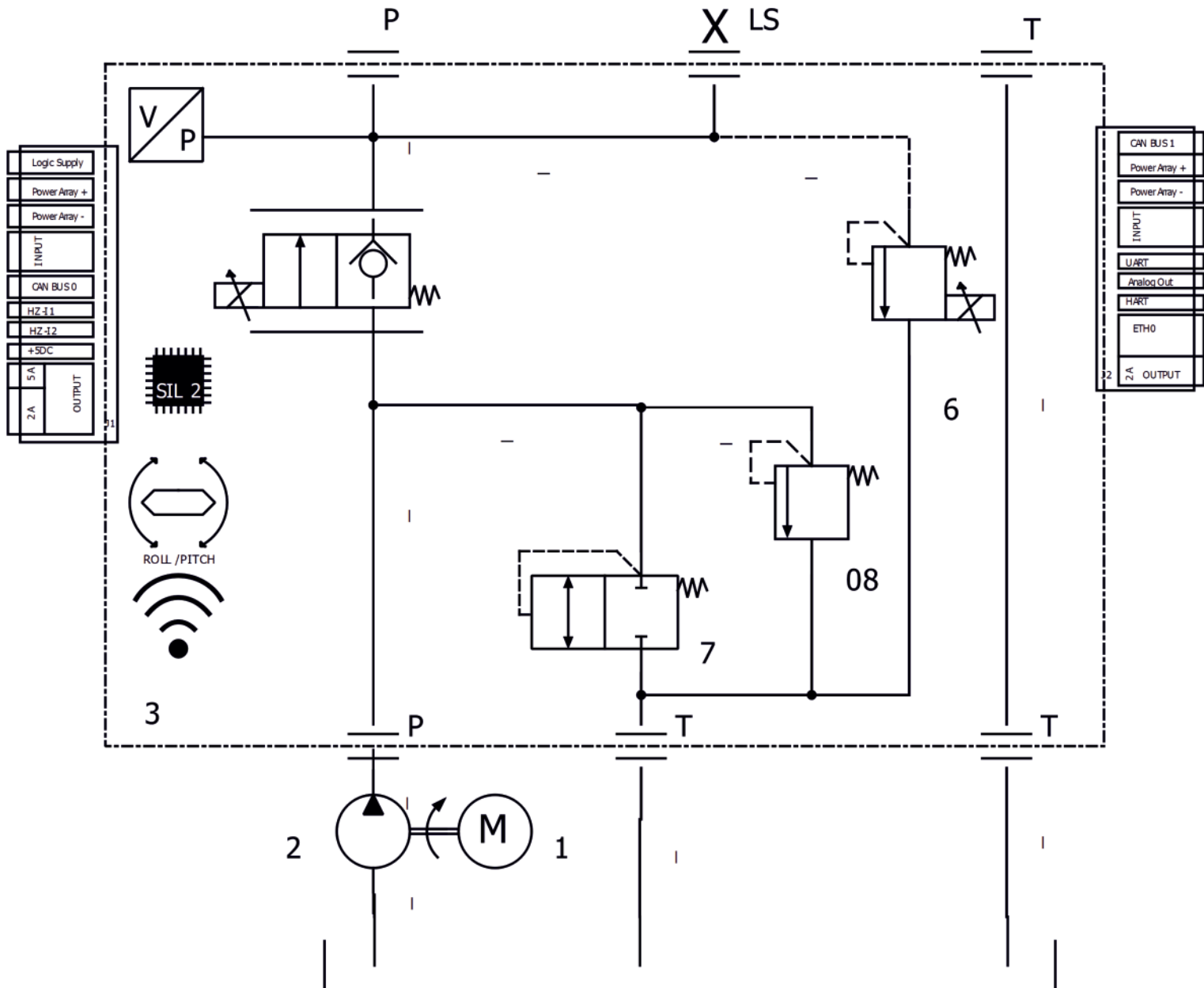

HPC02PQ: Hydraulic Diagram

The PQ type diagram is useful for sequential motion in automation, normally the PQ manifold feeds an array of ON-OFF directional valves, regulating the common flow and the max pressure. PQ system allows just sequential asynchronous movements. Typical applications are: personal lift equipment, small cranes,...

The Manifold contains a 3rd way pre-compensator which is sensing pressure across the proportional flow regulator. The proportional pressure relief valve is limiting the max pressure allowed on the system. Pressure sensors (rated for 300 bar) sense Delivery line (P) or Load Sensing Line (the other line being plugged); pressure sensor is rated for max 5 bar and senses the return line pressure. They are installed and electrically connected inside the manifold to the Logic controller. The Electronic Programmable controller drives the proportional valves according to the application software.

HPC02PQ with proportional meter-in Flow and Pressure controls

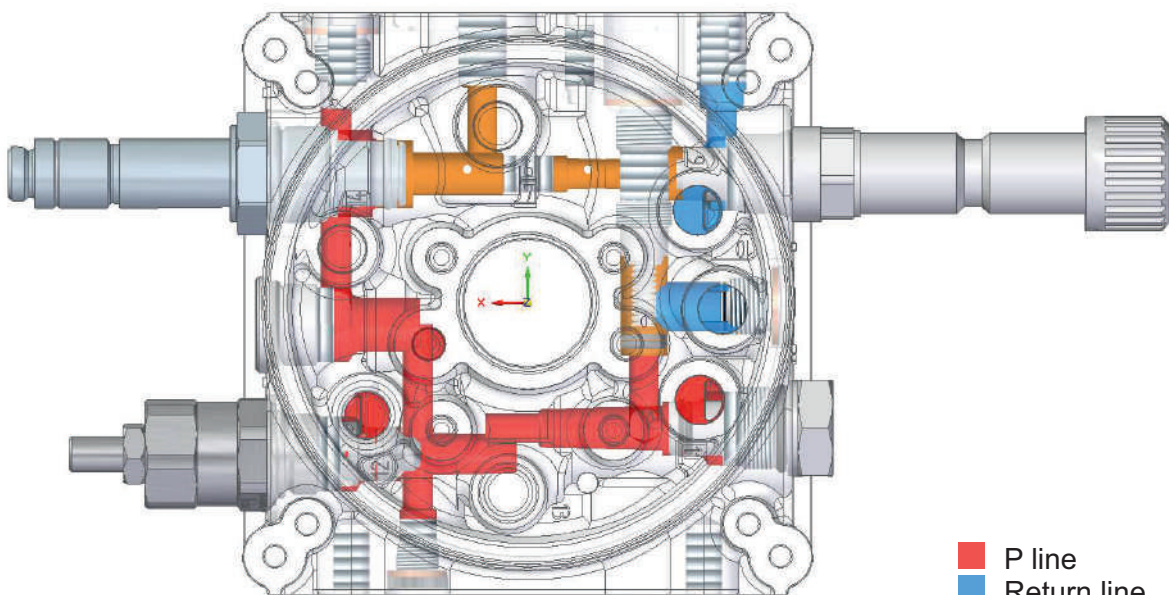
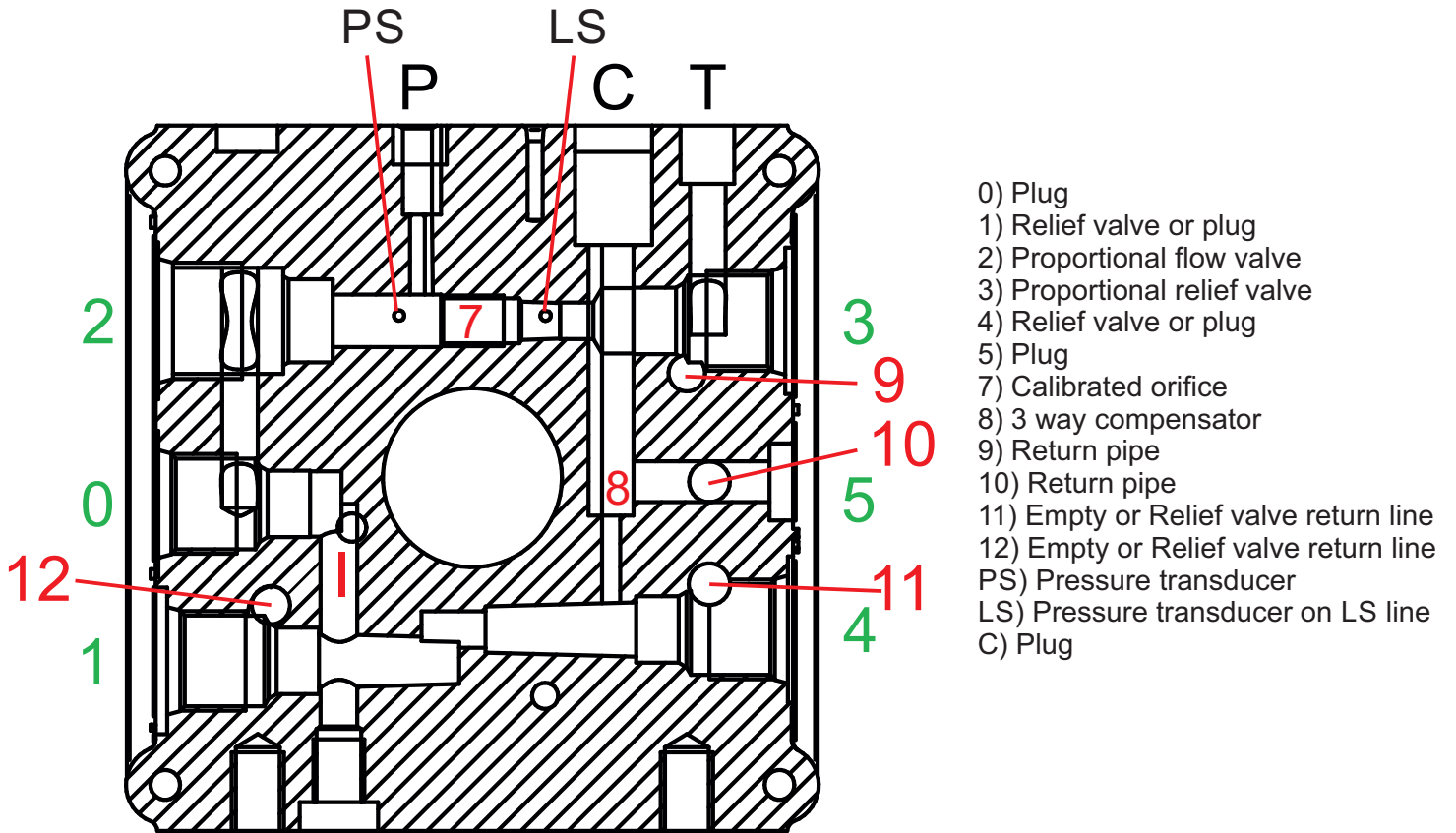

- P line
- Return line
- Reduced pressure line

SECTION A



HPC02LS with Load Sensing

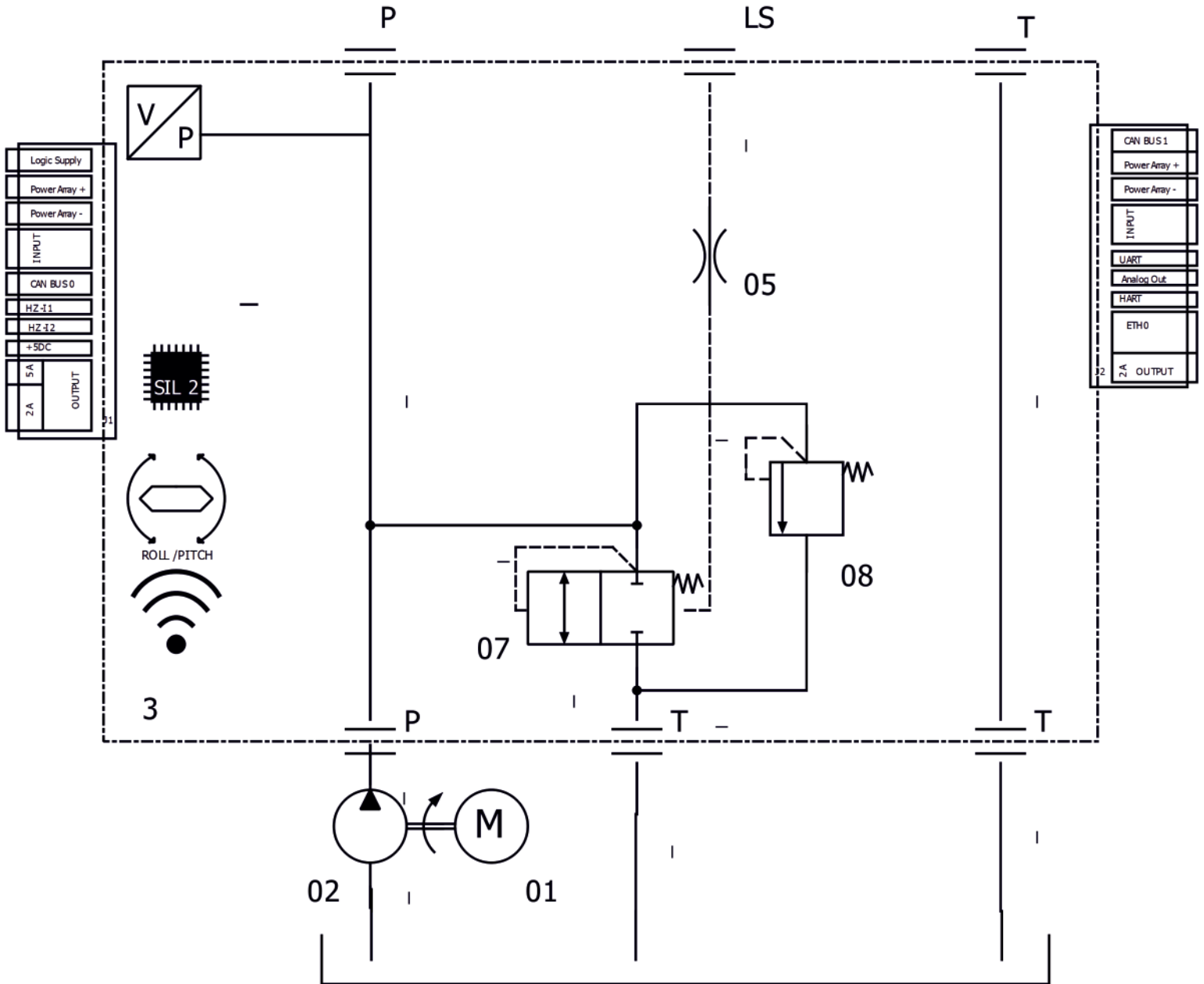

HPC02LS: Hydraulic Diagrams with Load Sensing for external proportional LS valves (type SDP02):

By replacing the Proportional Flow Control valve or/and the Proportional Pressure Relief valve with the related manual adjustment valves, and plugging/unplugging the LS lines, additional hydraulic configurations are available as well.

HPC02 is equipped with SAE08 normalised cavities in order to offer the maximum flexibility in configuration.

Also available with ON/OFF valves.

The Manifold contains a 3rd way pre-compensator which is sensing the load driven by LS line of the highest loaded valve.

Pressure sensors (rated for 300 bar) sense the Load Sensing Line (the other line being plugged); pressure sensor is rated for max 5 bar and senses the return line pressure.

They are installed and electrically connected inside the manifold to the Logic controller. The Electronic Programmable controller drives the proportional valves according to the application software.

HPC02LS with Load Sensing

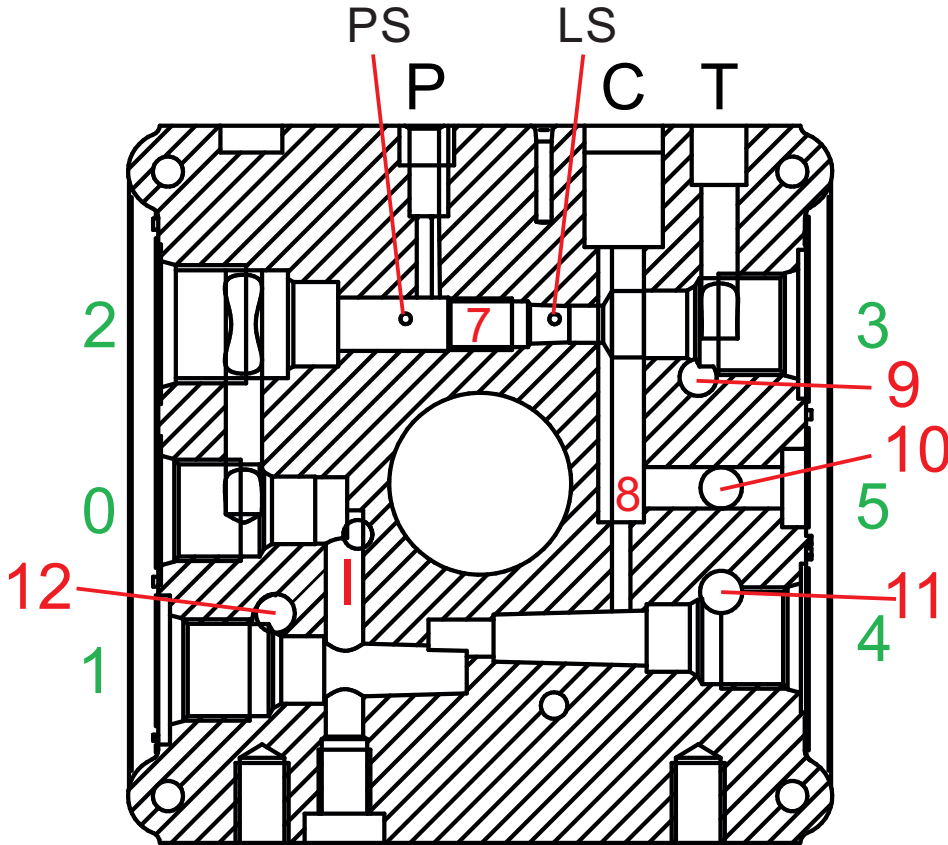

- 0) Plug
- 1) Relief valve or plug
- 2) 7/8"-14 UNF Plug
- 3) Plug
- 4) Relief valve or plug
- 5) Plug
- 7) Calibrated orifice
- 8) 3 way compensator
- 9) Return pipe
- 10) Return pipe
- 11) Empty or Relief valve return line
- 12) Empty or Relief valve return line
- PS) Pressure transducer
- LS) Pressure transducer on LS line
- C) Special Plug

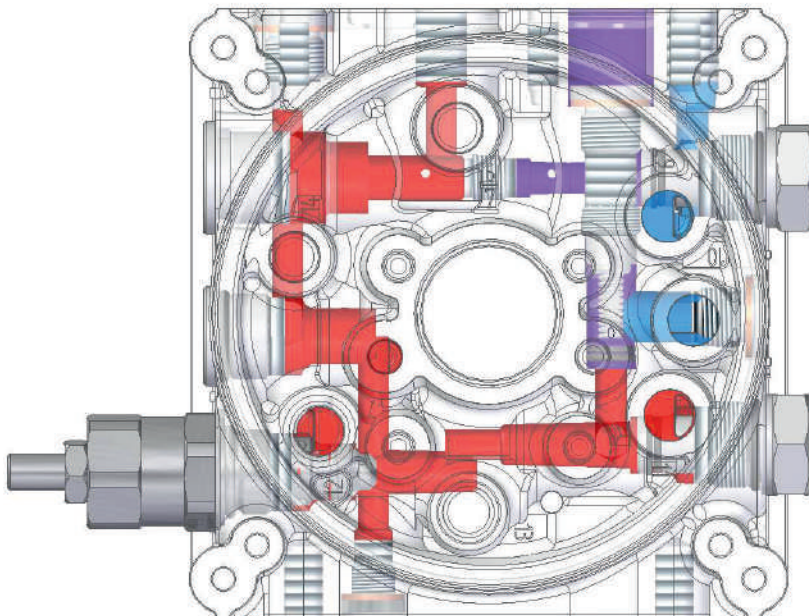

- P line
- Return line
- LS line

SECTION A



HPC02LSP with LS and proportional Pressure control

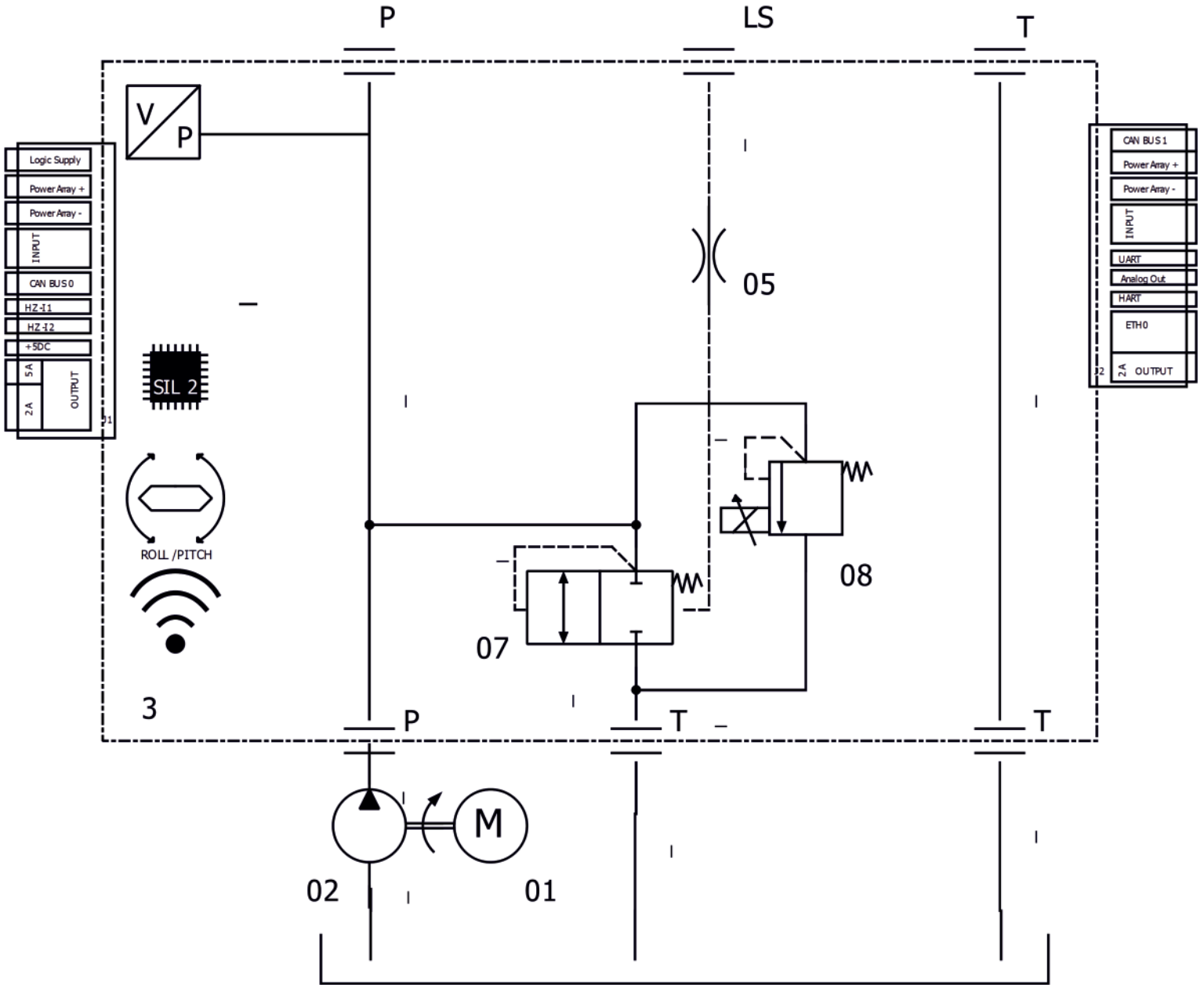

HPC02LSP: Hydraulic Diagram LS type for external proportional LS valves (type SDP02):

The LS type diagram is useful for simultaneous motion in automation, normally the PQ manifold feeds an array of Proportional or ON-OFF LS pre-compensated valves, regulating the common flow and the max pressure in the classic LoadSensing architecture. Contemporary movements are possible.

The Manifold contains a 3rd way pre-compensator which is sensing pressure across the proportional flow regulator. The proportional pressure relief valve is limiting the max pressure allowed on the system. Pressure sensors (rated for 300 bar) sense Delivery line (P) or Load Sensing Line (the other line being plugged); pressure sensor is rated for max 5 bar and senses the return line pressure. They are installed and electrically connected inside the manifold to the Logic controller. The Electronic Programmable controller drives the proportional valves according to the application software.

HPC02LSP with LS and proportional Pressure control

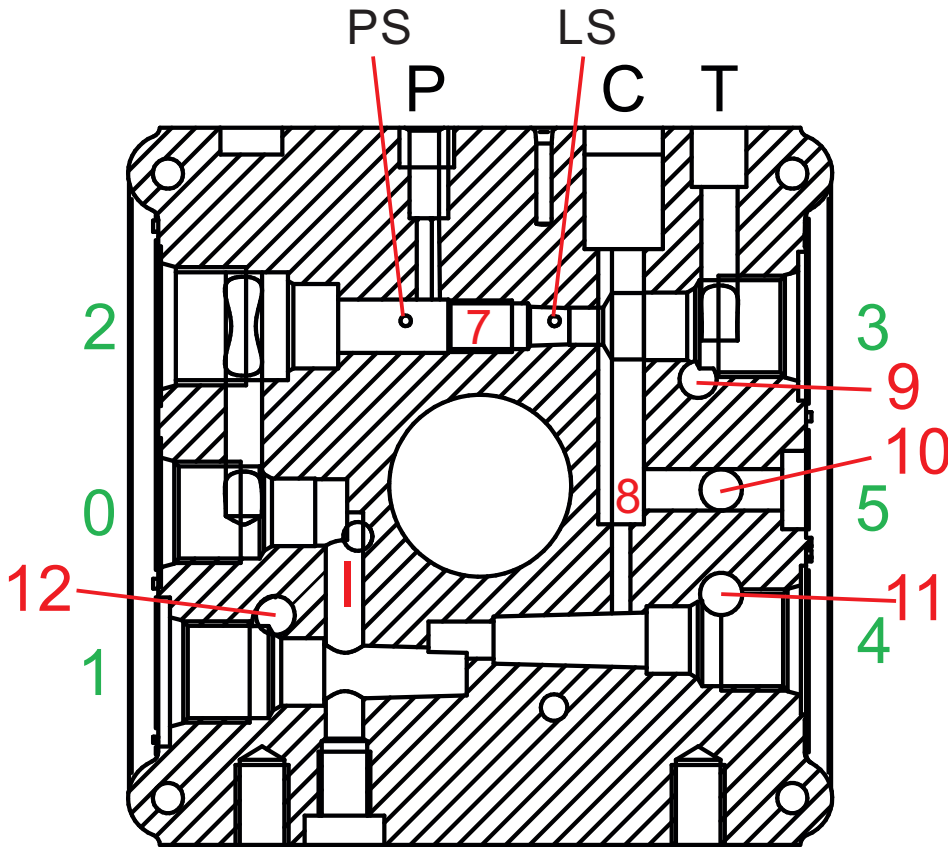

- 0) Plug
- 1) Relief valve or plug
- 2) 7/8"-14 UNF Plug
- 4) Relief valve or plug
- 5) Plug
- 7) Calibrated orifice
- 8) 3 way compensator
- 9) Return pipe
- 10) Return pipe
- 11) Empty or Relief valve return line
- 12) Empty or Relief valve return line
- PS) Pressure transducer
- LS) Pressure transducer on LS line
- C) Special Plug

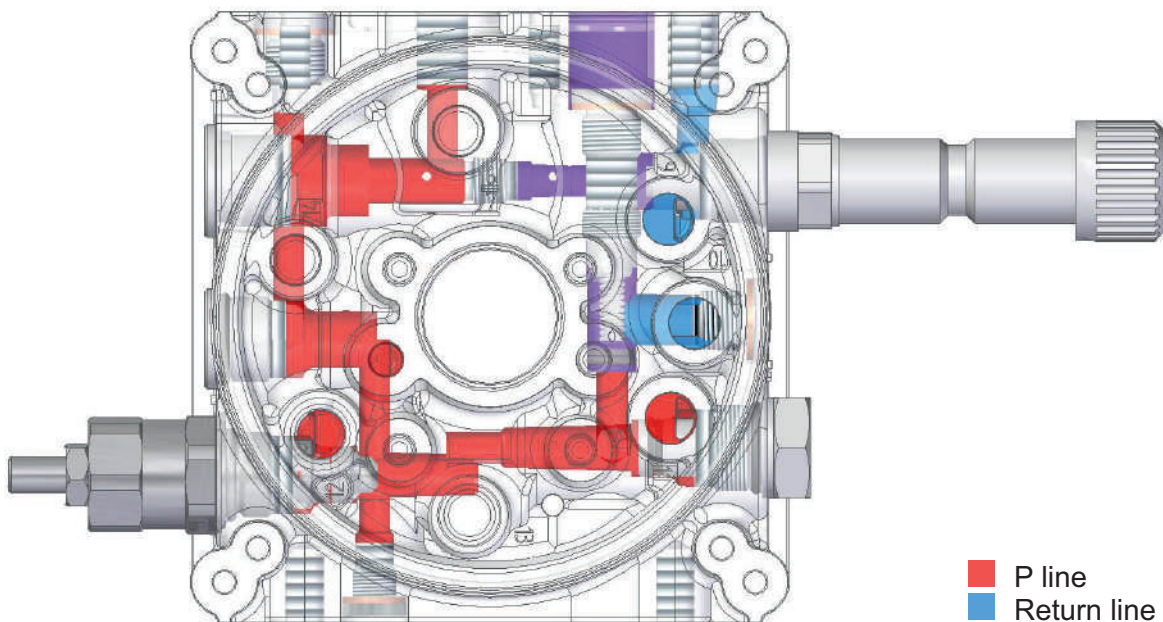

- P line
- Return line
- LS line

SECTION A



HPC02LSP with LS and proportional Pressure control

DISEGNO CORPO SPU CON POSSIBILI VALVOLE



SECTION A



HPC02LSP with LS and proportional Pressure control

MISURE DIMENSIONALI CORPO SPU

HPC02 CABLE AND CONNECTOR J1 TYPE

HPC02 electronic controller is equipped with a Molex 64319-3211 Connector in order to connect an external cable harness to the local I/O.

Cable Harness with one meter cable connected to the mating connector is available for small series or prototypes

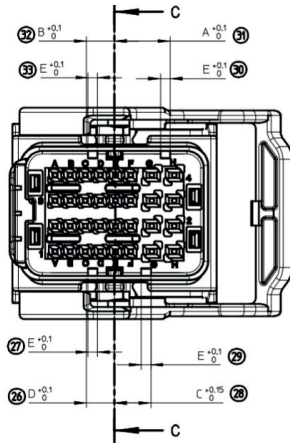

PIN	CONNECTOR	SIGNAL	DESCRIPTION
A1	J1	OUT3	Digital/PWM/Current loop output
A2	J1	OUT2	Digital/PWM/Current loop output
A3	J1	OUT1	Digital/PWM/Current loop output
A4	J1	OUT0	Digital/PWM/Current loop output
B1	J1	VBAT	+ Logic Power Supply
B2	J1	IN2	Digital/Analog input
B3	J1	IN1	Digital/Analog input
B4	J1	OUT4	Digital/PWM/Current loop output
C1	J1	GNCBAT	- Logic Power Supply
C2	J1	IN3	Digital/Analog input
C3	J1	RPM1H	Frequency input 1 High
C4	J1	OUT5	Digital/PWM/Current loop output
D1	J1	CAN0H	Can Bus line 0 High
D2	J1	IN4	Digital/Analog input
D3	J1	RPM1L	Frequency input 1 Low
D4	J1	OUT6	Digital/PWM/Current loop output
E1	J1	CAN0L	Can Bus line 0 Low
E2	J1	IN5	Digital/Analog input
E3	J1	RPM0L	Frequency input 0 Low
E4	J1	OUT7	Digital/PWM/Current loop output
F1	J1	IN0	Digital/Analog input
F2	J1	IN6	Digital/Analog input
F3	J1	RPM0H	Frequency input 0 High
F4	J1	5VDC	5 Vdc for external device
G1	J1	GND P1	- Power Supply (OUT0-OUT3)
G2	J1	GND P2	- Power Supply (OUT4-OUT7)
G3	J1	GND P4	- Power Supply (OUT5A)
G4	J1	PWR5A0	Digital output 5A
H1	J1	VPOWER1	+ Power Supply (OUT0-OUT3)
H2	J1	VPOWER2	+ Power Supply (OUT4-OUT7)
H3	J1	VPOWER4	+ Power Supply (OUT5A)
H4	J1	PWR5A1	Digital output 5A

SECTION A



HPC02 CABLE AND CONNECTOR J2 TYPE

HPC02 electronic controller is equipped with a Delphi Connector in order to connect an external cable harness to the local I/O.

Cable Harness with one meter cable connected to the mating connector is available for small series or prototypes

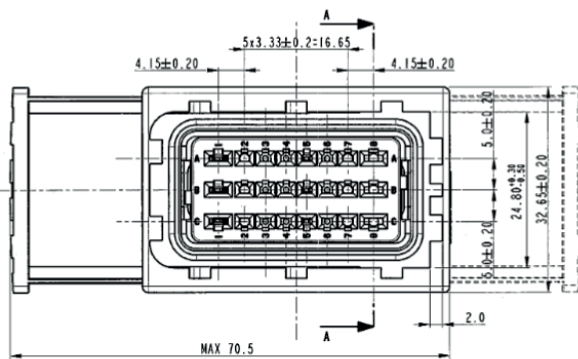

PIN	CONNECTOR	SIGNAL	DESCRIPTION
A1	J2	GNDP3	- Power Supply (OUT8-OUT11)
A2	J2	VPOWER3	+ Power Supply (OUT8-OUT11)
A3	J2		Not Used
A4	J2	CAN1H	Can Bus line 1 High
A5	J2		Not Used
A6	J2		Not Used
A7	J2	IN7	Digital/Analog input
A8	J2	IN8	Digital/Analog input
B1	J2	OUT9	Digital/PWM/Current loop output
B2	J2	OUT10	Digital/PWM/Current loop output
B3	J2		Not Used
B4	J2	CAN1L	Can Bus line 1 Low
B5	J2		Not Used
B6	J2		Not Used
B7	J2	IN9	Digital/Analog input
B8	J2	IN10	Digital/Analog input
C1	J2	OUT8	Digital/PWM/Current loop output
C2	J2	OUT11	Digital/PWM/Current loop output
C3	J2		Not Used
C4	J2		Not Used
C5	J2		Not Used
C6	J2		Not Used
C7	J2		Not Used
C8	J2	IN11	Digital/Analog input

HPC02 CABLE AND CONNECTOR M12 TYPE



HPC02 electronic controller is equipped with a M12 D code Connector in order to connect the HPC02 electronic controller to a ethernet.

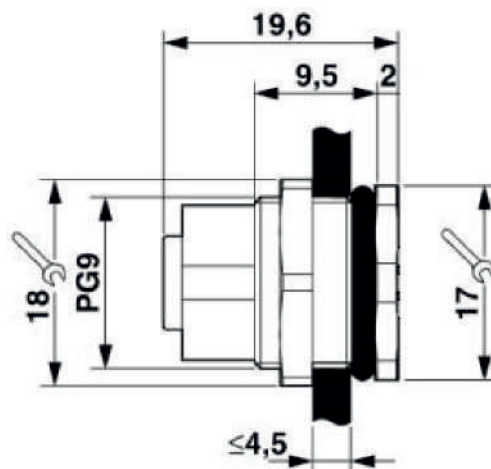
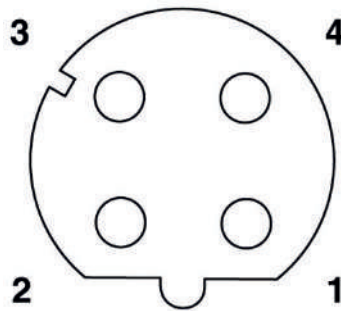

PIN	Signal
1	TxD+
2	RxD+
3	TxD-
4	RxD-

SECTION A



HPC200: I/O CAN-BUS EXTENDER



HPC200 is CANBUS Input Output Extender which can digitize analog or digital signal such as Pressure transducers, pressure switches, flow sensors, filter clogging sensors and so on and broadcast them to an external CAN-BUS controller such as our HPC or other. HPC moreover has digital Output suitable to direct drive solenoid or starter relays through CAN BUS. on request HPC200 can be equipped with simple software to perform simple tasks such as:

- local driver for remotely controlled hydraulic circuit: it replaces a box with 8 relays and fuses, can be controlled by a CAN BUS keyboard
- hydraulic accumulator charge cycle: it manage charging/discharging cycle of an hydraulic accumulator through the use of a pressure transducer
- sequence driver: it perform a sequence of operations to manage the complete machine.
- other logics can be programmed as per customer specification

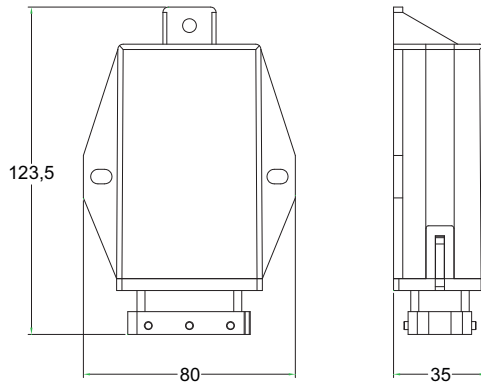

Main features

Power Supply	8 - 32 VDC
Operating temperature	-40°C / +80 °C
Ingress Protection	IP65
Connector	AMP 24 poles
Main CPU	Freescale 40MHz
Internal Memory	32K Flash (program)
	1KB EEPROM
RAM	2KB
RTC	on-board
Communication ports	1 CAN-BUS line
I/O List (optional)	6 Analog / Digital Input
	8 output High-Side 2A +5V sensors supply
EMC Standard	EN61000-2, 3, 4
MTTFd	53,42Y

PinOut	Function	PinOut	Function
1A	OUT7	5B	A-IN0
2A	OUT5	6B	CAN R2
3A	OUT4	7B	CAN L
4A	OUT3	8B	WDO-IN
5A	OUT2	1C	+VB
6A	OUT1	2C	+5V (50mA)
7A	OUT0	3C	D-IN1
8A	+VPower	4C	D-IN2
1B	-VB	5C	A-IN1
2B	OUT6	6C	CAN H
3B	D-IN0	7C	CAN R2
4B	D-IN1	8C	WDO-OUT



NOTES

A series of horizontal dotted lines for taking notes, spanning the width of the page.

HVI804: 4,3" PROGRAMMABLE COLOUR DISPLAY WITH CAN BUS



HVI804 is a 4,7" LCD Colour display with Capacitive Touchscreen function. This display is equipped with an ARM926 processor and it is programmable with OPEN-PLC including graphic libraries based on QT.

The display area is QSVGA, with high contrast for good visibility under direct sunlight.

HVI804 is the ideal interface of the Hydronit Smart Power Unit, with possibility to show a big variety of machine information within a customized colorful display. Connection is granted through CAN-BUS line, and USB.

HVI804 is equipped with Ethernet port, for IoT applications as DataLogging etc.

Main features

Power Supply	12 - 36 VDC
Operating temperature	0°C / +50 °C
Ingress Protection	IP65
Main CPU	ARM926 - 454Mhz
Internal Memory	128MB Flash
	128MB DRAM
RAM	128MB
Display	4,3"- 480 x 272 px
Communication ports	1 micro USB port
	1 CAN OPEN
	1 Ethernet Port
IDE	IEC61131-3

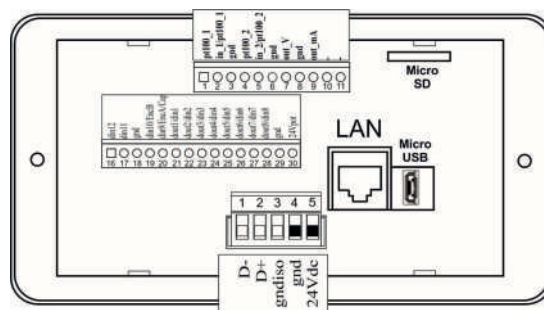
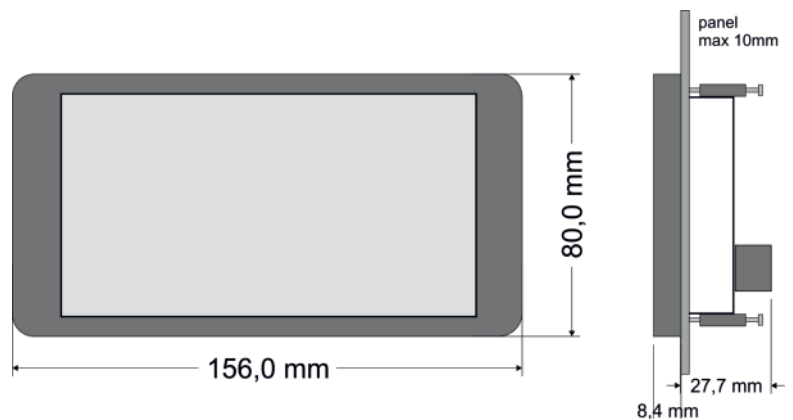

Model with CANbus

CONNECTOR	PIN	FUNCTION
M1	1	CAN H
M1	2	CAN L
M1	3	GND ISO
M1	4	0V
M1	5	+ V

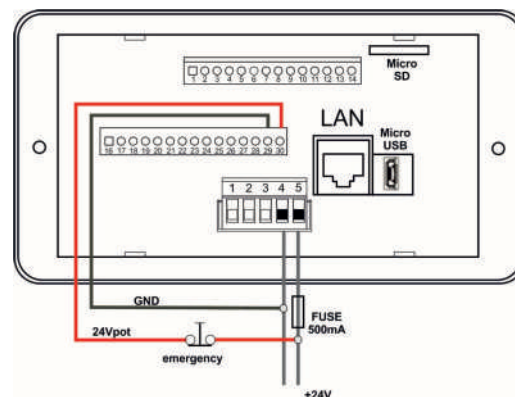

SECTION B



HVI807: 7" PROGRAMMABLE COLOUR TOUCHSCREEN WITH ETHERNET



HVI807 is a 7" LCD Colour display with Capacitive Touchscreen function. This display is equipped with an ARM926 processor and it is programmable with OPEN-PLC including graphic libraries based on QT.

The display area is QSVGA, with high contrast for good visibility under direct sunlight.

HVI807 is the ideal interface of the Hydronit Smart Power Unit, with possibility to show a big variety of machine information within a customized colourful display. Connection is granted through CAN-BUS line, Modbus and USB.

HVI807 is equipped with Ethernet port, for IoT applications as DataLogging etc.

Main features

Power Supply	12 - 36 VDC
Operating temperature	0°C / +50 °C
Ingress Protection	IP65
Main CPU	ARM926 - 454Mhz
Internal Memory	1GB SDRAM, 2GB SD card
Display	7"- 800 x 480 px
RAM	128MB
Communication ports	1 micro USB port 1 CAN OPEN 1 Ethernet Port
IDE	IEC61131-3

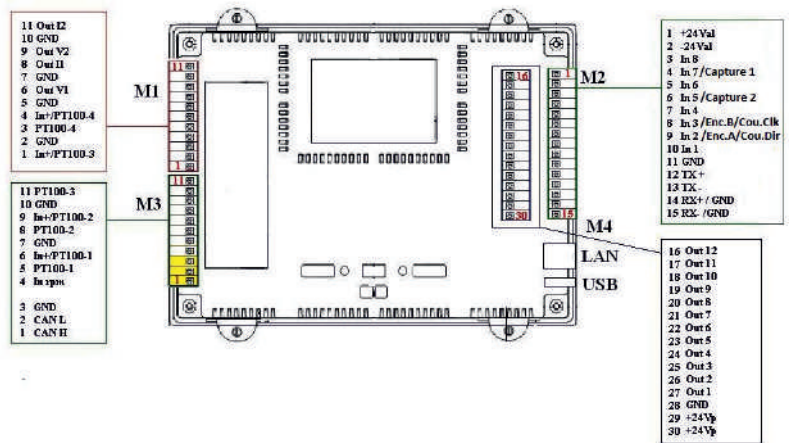
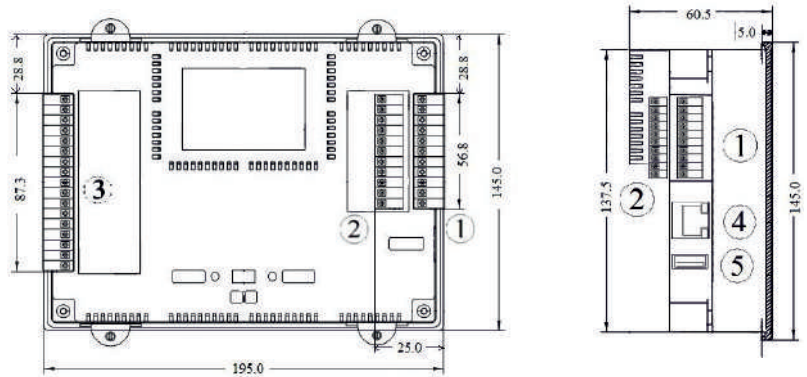

CONNECTOR	PIN	FUNCTION
M3	1	CAN H
M3	2	CAN L
M3	3	GND
M2	1	+ V bat
M2	2	- V bat
M2	11	GND
M2	12	TX +
M2	13	TX -
M2	14	RX +
M2	15	RX -

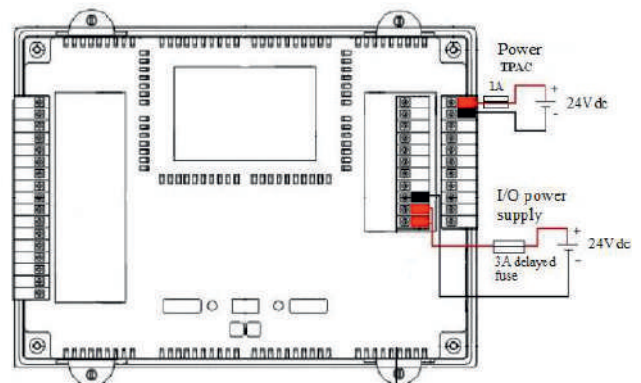

HVI203: 3" PROGRAMMABLE DISPLAY WITH TOUCHSCREEN WITH CAN BUS



HVI203 is a 3" dot matrix black/white display with touchscreen. This display is equipped with a Freescale HSC processor, which is programmable with a specific IDE environment available on request. HVI203 is including additional I/O ports for local data acquisition of hardware switches. The display area is 176 x 80mm and is best performing for small graphic and simple icons.

HVI203 is perfect as a "content sensitive keyboard": the touchscreen area can be programmed in order to simulate from 2 to 10 virtual buttons with variable icons depending on the machine function.

HVI203 is equipped with CAN-Bus line which enable connection between with the controller with just 2 twisted wires. HVI203 is equipped with a local buzzer and backlight.

HVI203 can be installed in a panel and fixed through built-in plastic clips. as option a RAM Mount is available on request.

Main features

Power Supply	8 - 32V
Operating temperature	-30 °C / +75 °C
Ingress Protection	IP65
Connector	DT06-08SA
Display dot matrix	3" - 176 x 80
Backlight	LED
Buzzer	integrated
Installation	panel or pedestal
Input	2 analog, 1 digital
Communication	1 CAN-Bus
Option	Touchscreen

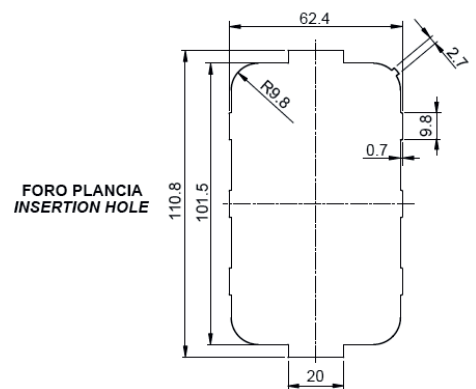
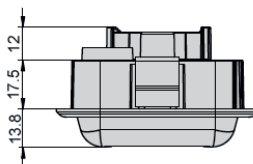
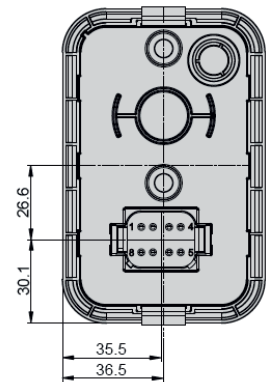
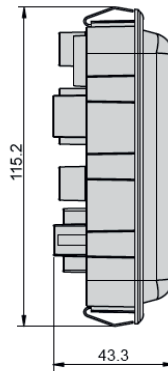
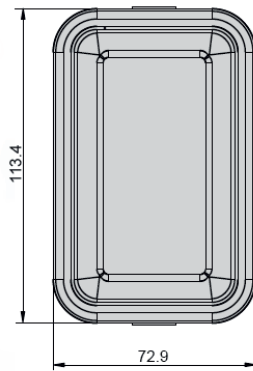

HSD-RP01



HSD-RP01 is a Roll / Pitch sensor with CAN-BUS connection. It uses a temperature compensated accelerometric angle sensor, with high accuracy and repeatability. The sensor is equipped with a built in microprocessor that grants compensation and connectivity. An armoured body is ideal for rough hydraulic application such as levelling systems for trucks. The device is fully potted of resin and it is connected through a M12 connector

Main features

Power Supply	8 - 32 VDC
Operating temperature	-40°C / +70 °C
Ingress Protection	IP66
Connector	M12x1 5poles male A
Sensing Range	+/- 60° on X and Y
Accuracy	0,3°
Thermal Drift	+/- 0,001 deg/°C
Vibration resistance	EN60068-2-6
EMC Standard	EN61000-6-2; -4
MTTFd	220Y

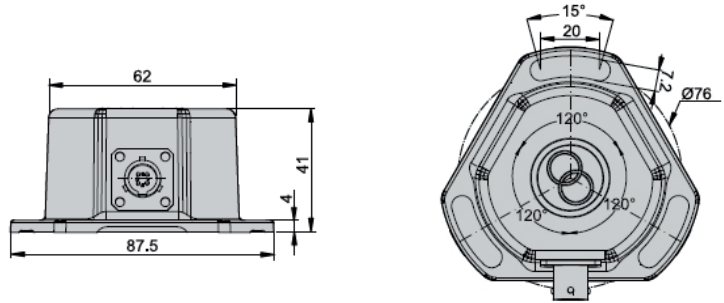

PinOut Function

PinOut	Function
1	NC
2	+VB
3	-VB
4	CAN H
5	CAN L



NOTES

A series of horizontal dotted lines provided for taking notes, spanning the width of the page.

HMI-304 CAN-BUS KEYBOARD



HMI-304 is a CANBUS keyboard with four toggle switches, packed in a ruggedized enclosure. It is developed for OUTDOOR environment, with extended water and temperature resistance.

Big keys allow a reliable pressure sensation even with working gloves. Each key can be customised with a plastic insert wich allow a perfect match with the machine features driven by Hydronit SMART POWER UNIT. More than 200 symbols are available in order to control the machine. If a symbol is not present in our database, we can produce it on request. The keys are backlit and multiple colours can be driven by the main controller.

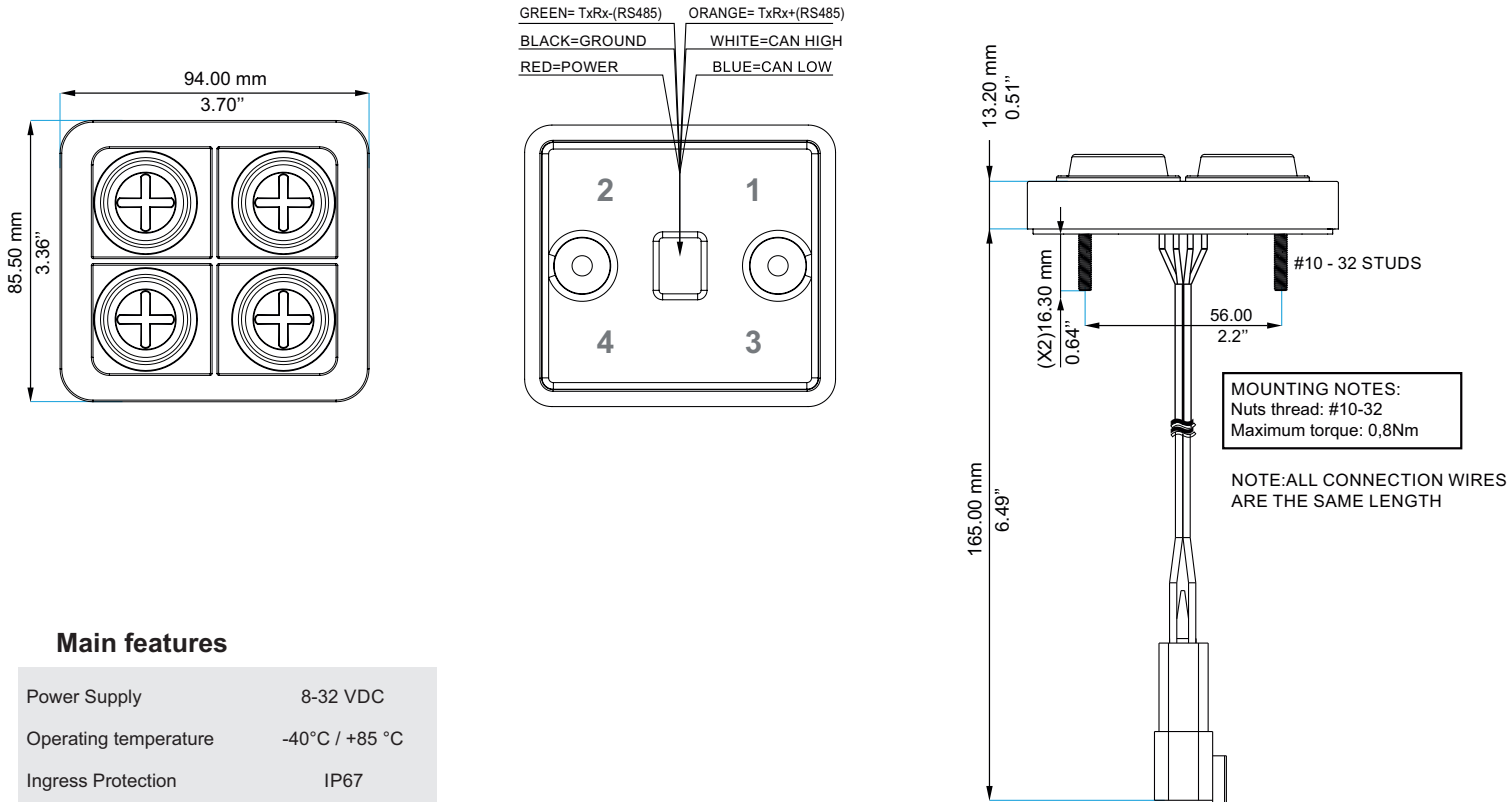

Main features

Power Supply	8-32 VDC
Operating temperature	-40°C / +85 °C
Ingress Protection	IP67
Connector	DT04-4P
Communication	CAN OPEN RS485

PinOut	Function
1	CAN L
2	CAN H
3	-VB
4	+VB
green cable	TxRx(RS485)
orange cable	TxRx(RS485)

SECTION D



HMI-308 CAN-BUS KEYBOARD



HMI-308 is a CAN BUS keyboard with 8 toggle switches, packed in a ruggedized enclosure. It is developed for OUTDOOR environment, with extended water and temperature resistance.

Big keys allow a reliable pressure sensation even with working gloves. Each key can be customised with a plastic insert which allow a perfect match with the machine features driven by Hydronit SMART POWER UNIT. More than 200 symbols are available in order to control the machine. If a symbol is not present in our database, we can produce it on request. The keys are backlit and multiple colours can be driven by the main controller.

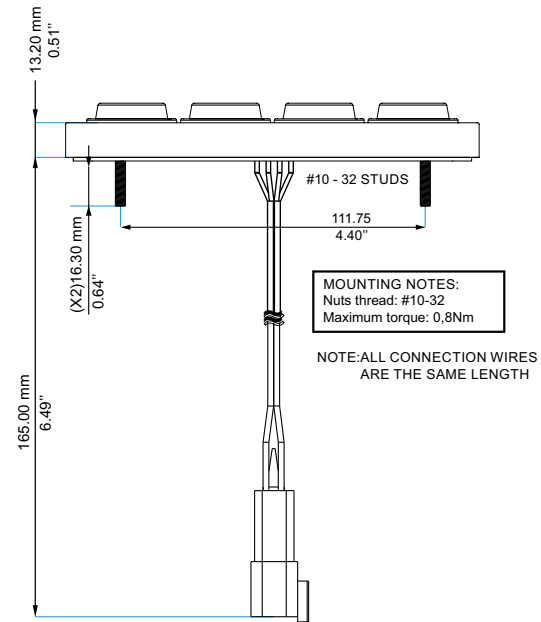
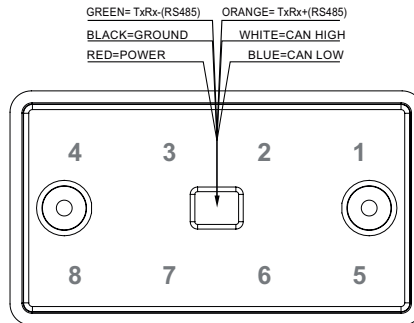
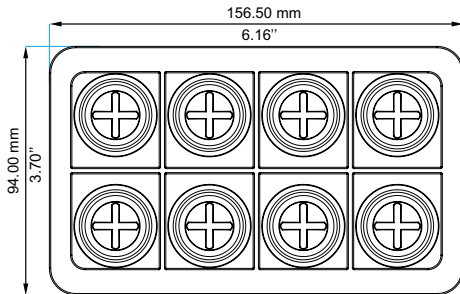

Main features

Power Supply	8-32 VDC
Operating temperature	-40°C / +85 °C
Ingress Protection	IP67
Connector	DT04-4P
Communication	CAN OPEN RS485

PinOut Function

PinOut	Function
1	CAN L
2	CAN H
3	-VB
4	+VB
green cable	TxRx(RS485)
orange cable	TxRx(RS485)

BASE MANIFOLD CONVERTERS



Dimensions in mm (inches)

SPU TO SD02LS STACKABLE VALVE CONVERTER
(needed to mount SD02LS stackable valves)

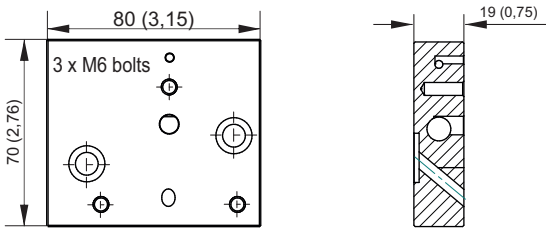

Fixing system: 2 M8x25 bolts steel class 8.8 or above
Weight: 0,25 Kg

Spare part code

EMPAH00015



Dimensions in mm (inches)

PPC TO SD02 STACKABLE VALVE CONVERTER
(needed to mount SD02 stackable valves)

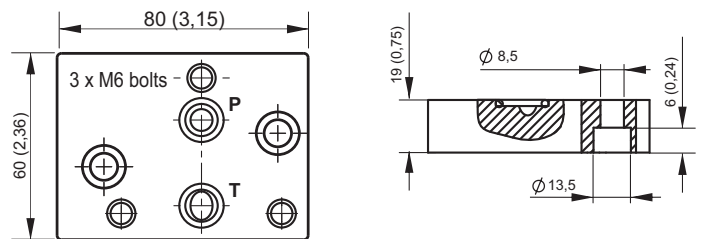

Fixing system: 2 M8x20 bolts steel class 8.8 or above
Weight: 0,22 Kg

Spare part code

E60403006DN



Dimensions in mm (inches)

SPU TO PPM BASE CONVERTER
(needed to mount PPM blocks to SPU manifold)

SPU INTERFACE

PPM INTERFACE

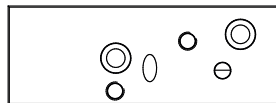
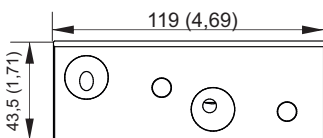

Fixing system: 2 M8x30 bolts steel class 8.8 or above
Weight: 0,28 Kg

Spare part code

EMPAH00004

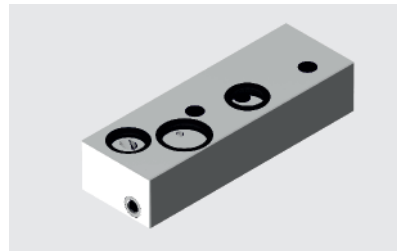

Dimensions in mm (inches)

SPU TO PPC BASE CONVERTER
(needed to mount PPC blocks to SPU manifold)

SPU INTERFACE

PPC INTERFACE

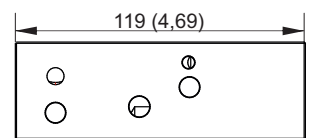
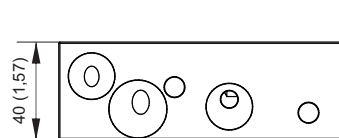

Weight: 0,33 Kg

Spare part code

EMPAH00003

Note: Recommended tightening torque for M8 bolts: 16 Nm. Attention! Do not use tie-rods less than 8.8.

MODULAR MANIFOLDS NG6 (CETOP 3), LATERAL PORTS



Dimensions in mm (inches)

Main features

Max pressure	350 bar
Weight	0,56 Kg (1,2lb)
Fixing bolts	2 M8 tie - rods steel class 8.8 or above

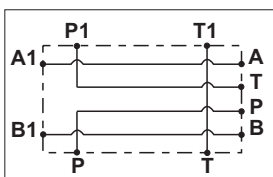
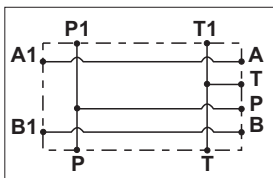
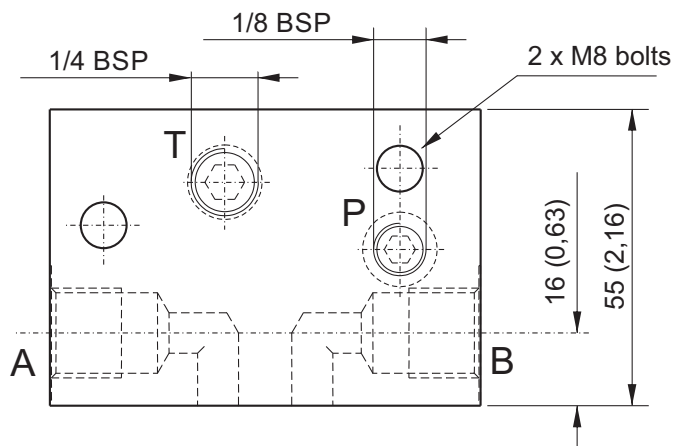
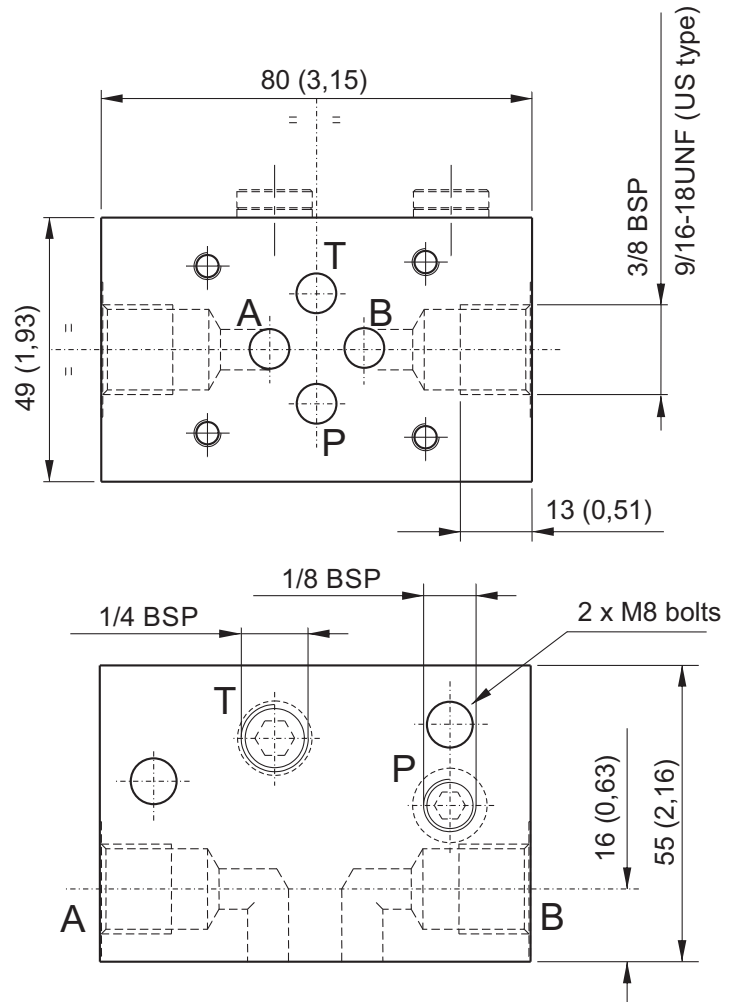

Parallel connection	Spare part code
Lateral ports	E60403010
Lateral port US execution	E60403010US

Series connection	Spare part code
Lateral ports	E60403011
Lateral port US execution	E60403011US

Option 1/4" BSP P port:

Spare part code
PORTMF0001

Note: Recommended tightening torque for M8 bolts: 16 Nm. Attention! Do not use tie-rods less than 8.8.

*: US execution with 9/16-18UNF SAE06 exit ports

To add external manifolds to a PPC assembly code, just add their spare part codes at the end of the PPC code. eg: PPC-0,8 12DC-MB-J-K0,6-V200-G-RETURN KIT-1,5L+E60403004+E60403010.

The Cetop attachment is on motor side. With AC motor frames bigger than 71 and DC motors bigger than dia. 125mm, always add a spacer manifold (see E60403004 code in F section) below the Cetop manifold to avoid interference between the valve and the motor. Code does not include the Cetop solenoid valve. See NG6 (Cetop 3) valves table in section G.

DA GUARDARE LE NOTE

MODULAR MANIFOLDS NG6 (CETOP 3) WITH INTEGRAL PILOT OPERATED CHECK VALVES



Dimensions in mm (inches)

Main features

Max pressure	350 bar
Pilot ratio	1:5,6
Weight	0,71 Kg (1,56lb)
Fixing bolts	2 M8 tie - rods steel class 8.8 or above

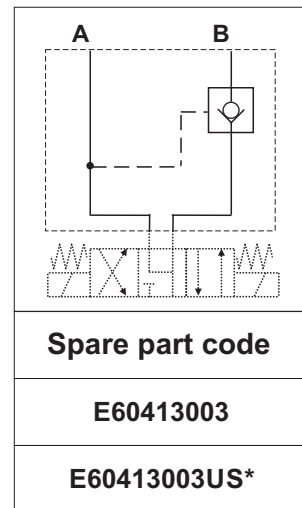
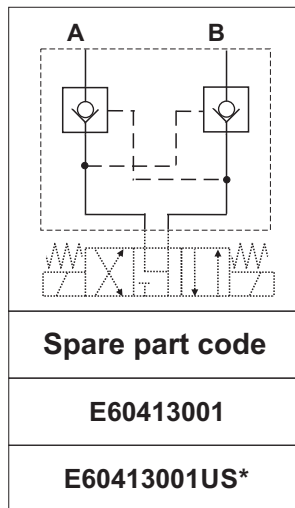
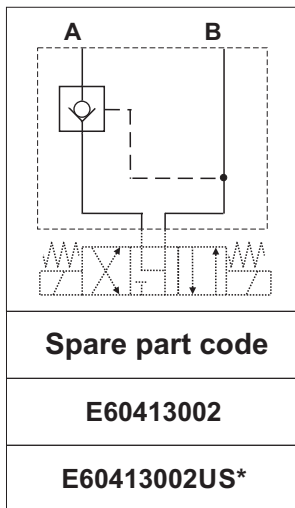
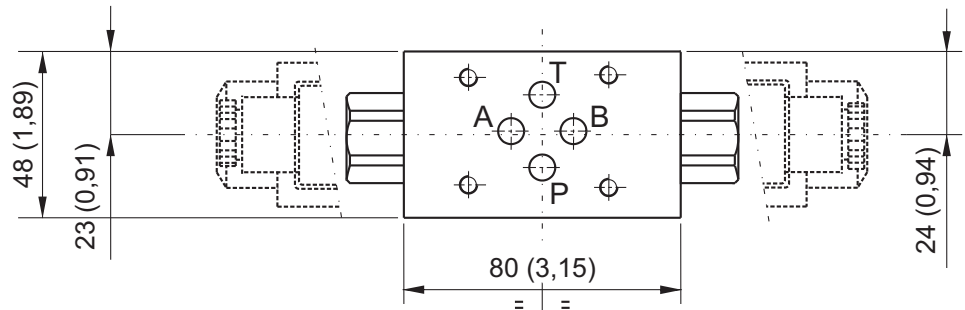
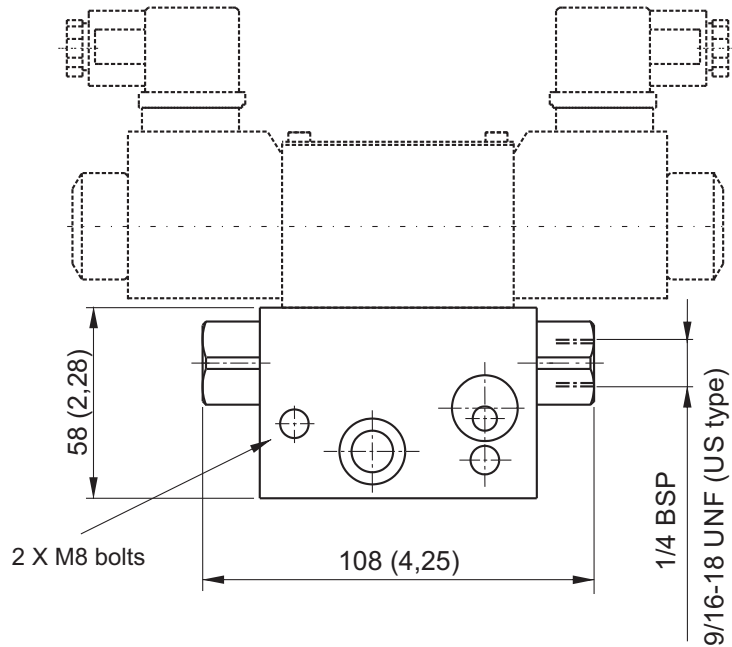

Note: Recommended tightening torque for M8 bolts: 16 Nm. Attention! Do not use tie-rods less than 8.8.

*: US execution with 9/16-18UNF SAE06 exit ports

To add external manifolds to a PPC assembly code, just add their spare part codes at the end of the PPC code. eg: PPC-0,8 12DC-MB-J-K0,6-V200-G-RETURN KIT-1,5L+E60403004+E60413001.

Code does not include the Cetop solenoid valve. See NG6 (Cetop 3) valves table in section G.

DA GUARDARE LE NOTE

SPACER ELEMENTS



Dimensions in mm (inches)

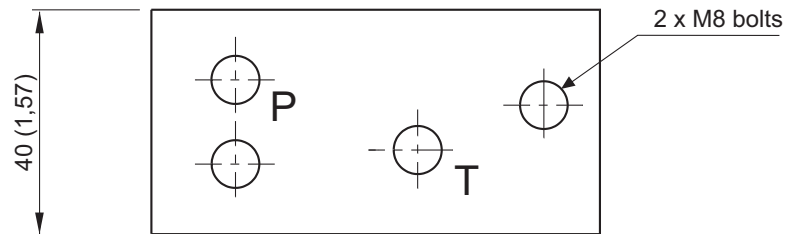
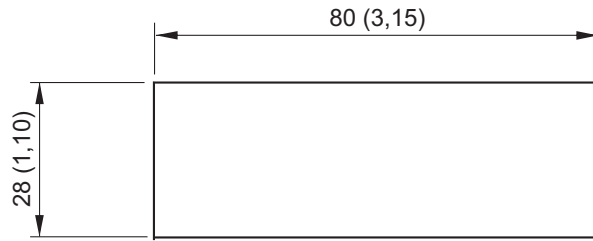

Main features

Max pressure	350 bar
Weight	0,23 Kg (0,5lb)
Fixing bolts	2 M8 tie - rods steel class 8.8 or above

Mounting example

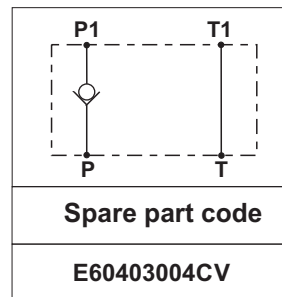
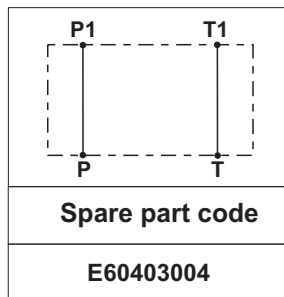
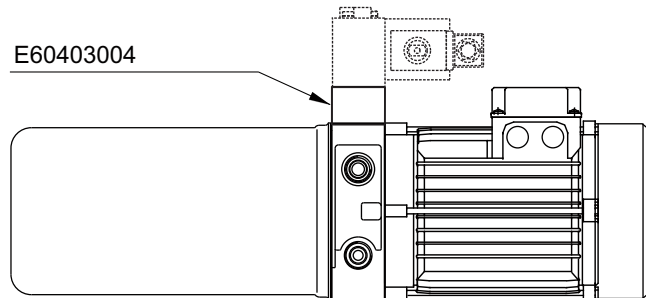

Note: Recommended tightening torque for M8 bolts: 16 Nm. Attention! Do not use tie-rods less than 8.8. Suitable with AC motor frames bigger than 71 and DC motors bigger than dia. 125, to avoid interference between the valves and the motor.

DA GUARDARE LE NOTE

NG3 MICRO MODULAR MANIFOLDS, LATERAL PORTS

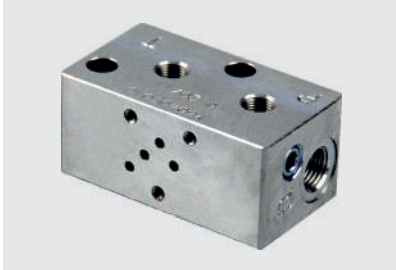

Dimensions in mm (inches)

Main features

Max pressure	350 bar
Weight	0,21 Kg (0,46lb)
Fixing bolts	2 M8 tie - rods steel class 8.8 or above

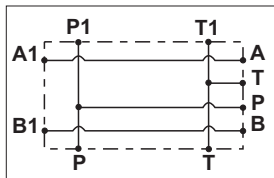
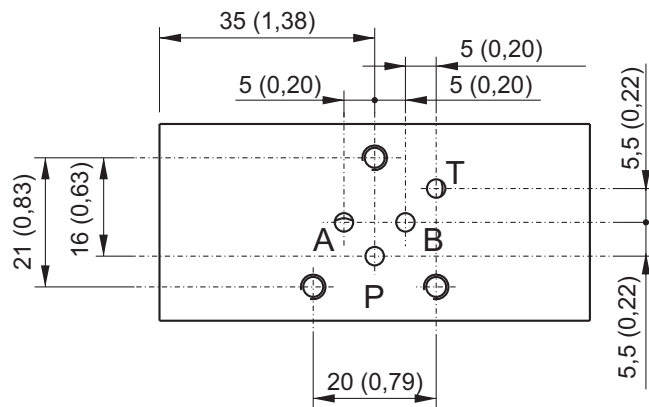
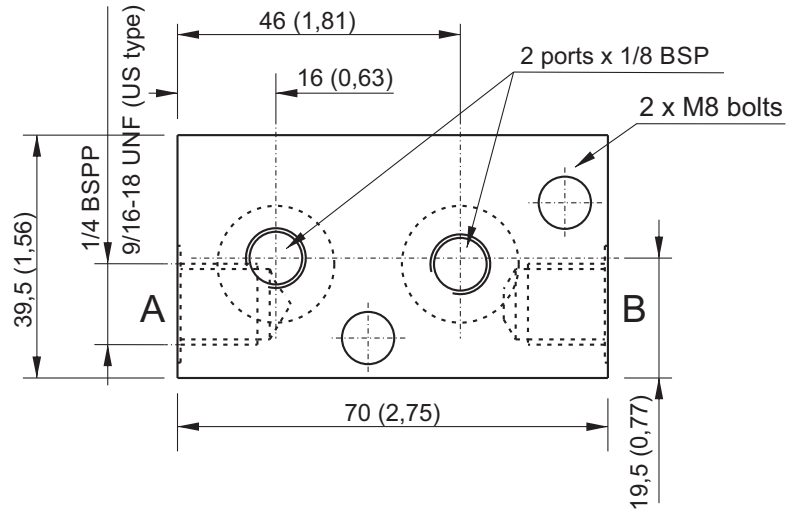

Parallel connection	Spare part code
Lateral ports	M60403010
Lateral ports US execution	M60403010US

DA GUARDARE LE NOTE

Note: Recommended tightening torque for M8 bolts: 16 Nm. Attention! Do not use tie-rods less than 8.8. To add NG3 MICRO external manifolds to a PPC assembly code, just add the converter PPC to PPM first, then the additional manifolds spare part codes at the end of the PPC code. eg: PPC-0,8 12DC-MB-J-K0,6-V200-G-RETURN KIT-1,5L+E60403008M+M60403004+M60403010. The NG3 micro valve attachment is on motor side.

NG3 MODULAR MANIFOLD WITH INTEGRAL PILOT OPERATED CHECK VALVES



Dimensions in mm (inches)

Main features

Max pressure	350 bar
Weight	0,26 Kg (0,57lb)
Fixing bolts	2 M8 tie - rods steel class 8.8 or above

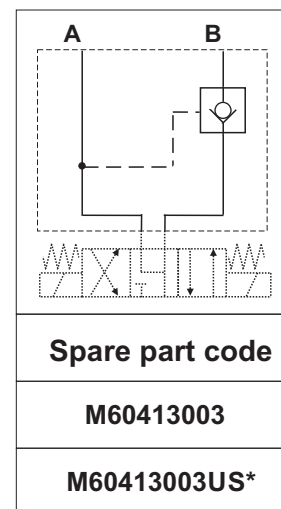
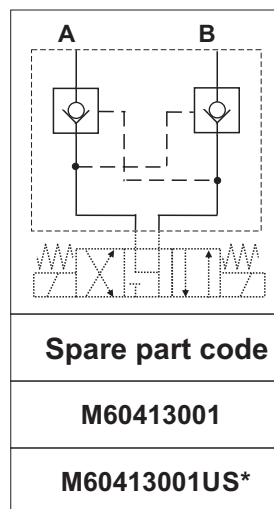
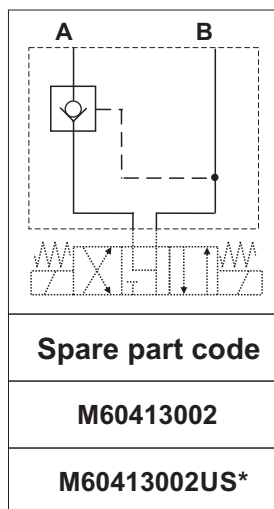
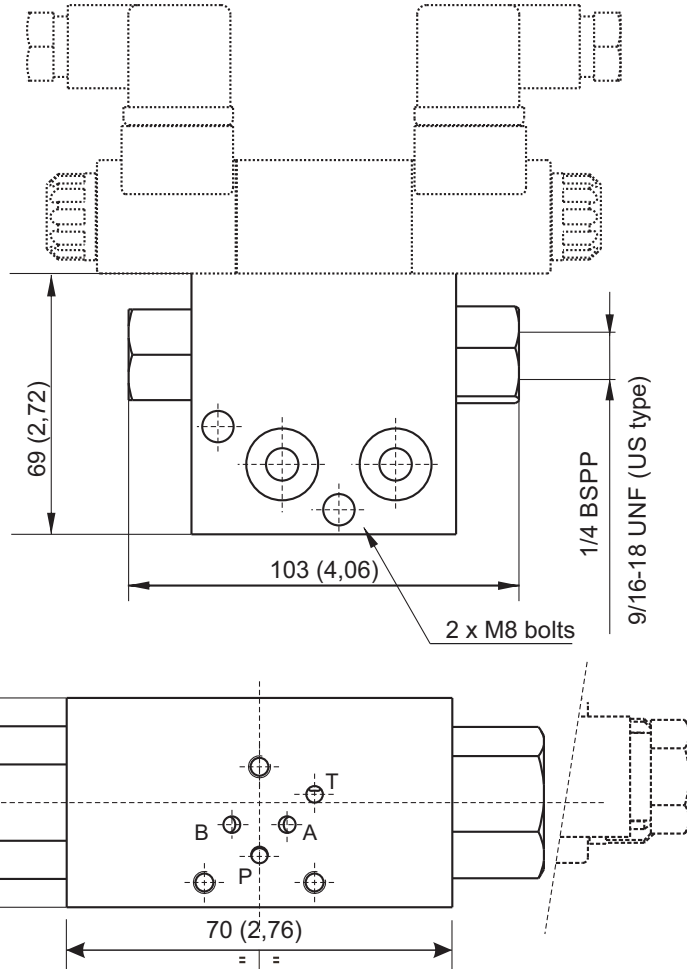

Note: Recommended tightening torque for M8 bolts: 16 Nm. Attention! Do not use tie-rods less than 8.8.

*: US execution with 9/16-18UNF SAE06 exit ports

To add NG3 MICRO external manifolds to a PPC assembly code, just add the converter PPC to PPM first, then the additional manifolds spare part codes at the end of the PPC code. eg: PPC-0,8 12DC-MB-J-K0,6-V200-G-RETURN KIT-1,5L+E60403008M+M60403004+M60403010.

Code does not include the NG3 valve. See SD00 NG3 valves table in section G.

DA GUARDARE LE NOTE

PPM SPACER ELEMENT 23MM

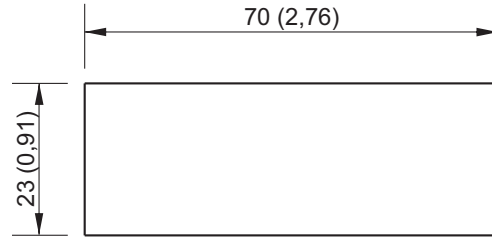
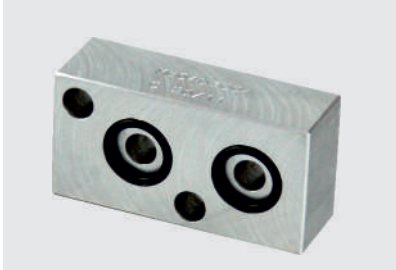

Dimensions in mm (inches)

Main features

Max pressure	350 bar
Weight	0,14 Kg (0,3lb)
Fixing bolts	2 M8 tie - rods steel class 8.8 or above

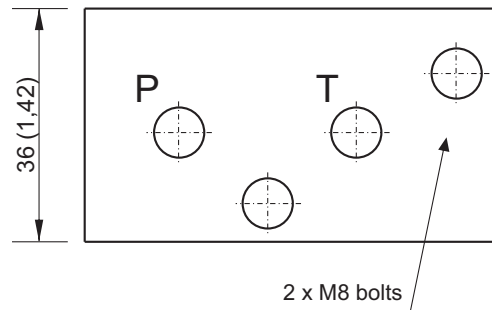

Mounting example

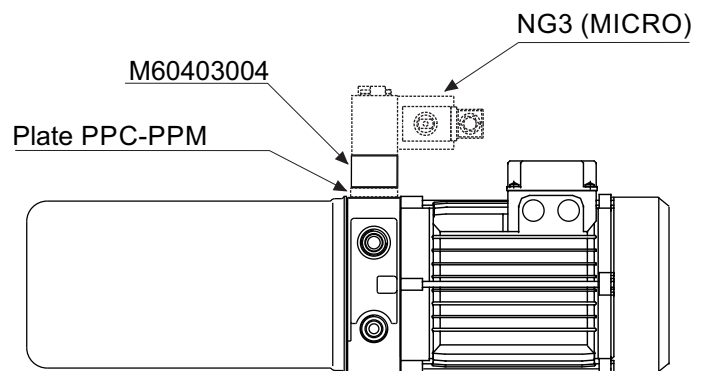
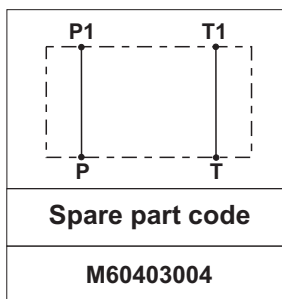

DA GUARDARE LE NOTE

Note: Recommended tightening torque for M8 bolts: 16 Nm. Attention! Do not use tie-rods less than 8.8.
 To add NG3 MICRO external manifolds to a PPC assembly code, just add the converter PPC to PPM first, then the additional manifolds spare part codes at the end of the PPC code. eg: PPC-0,8 12DC-MB-J-K0,6-V200-G-RETURN KIT-1,5L+E60403008M+M60403004+M60403010.

STACKABLE ON-OFF ELECTROVALVE with LOAD SENSING

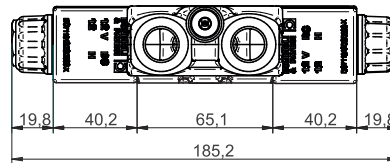
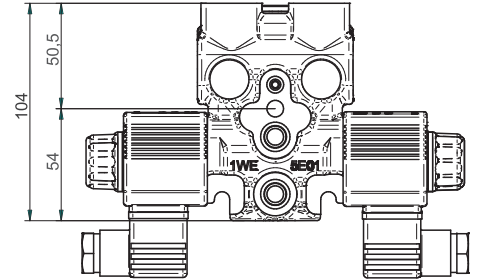
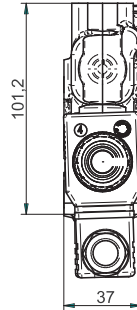
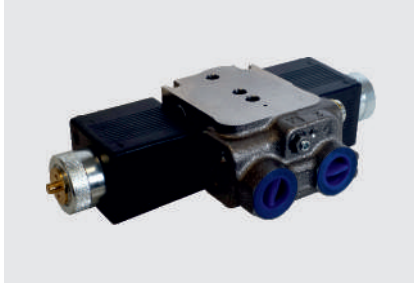

Main features

Max pressure	250 bar
Max pressure on T port	50 bar
Max flow	up to 40 l/min
Weight	1,6 Kg
Internal leakage	0,04 l/min at 100bar
Coil insulation	Class H
Electric connection	DIN 43650-A / ISO 4400
Protection class	IP 65 / DIN 40050
Duty cycle	ED 100%
Voltage required	+/- 10% nominal voltage
Manual Override	push
Standards	EN50081-1 / EN50082-2 (89/336 CEE electromagnetic comp.) 73/23/CEE / 96/68/CEE (low voltage)

Code

- SD02** — Stackable directional on-off valve
- E2** — Spool configuration see table below
- TP** — Top Port
- LS** — Load Sensing
- 24DC** — Supply voltage 12VDC or 24VDC

Spool



Hydraulic scheme

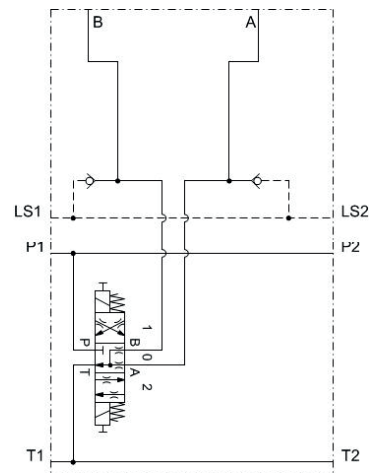

For valves mounting blocks see Power Pack Compact catalogue.

SECTION E



STACKABLE PROPORTIONAL ELECTROVALVE with LOAD SENSING

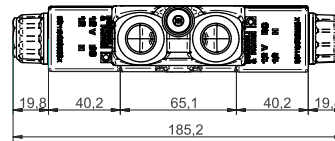
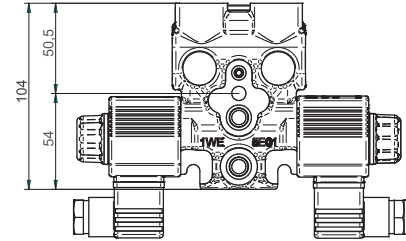
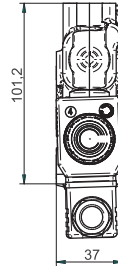
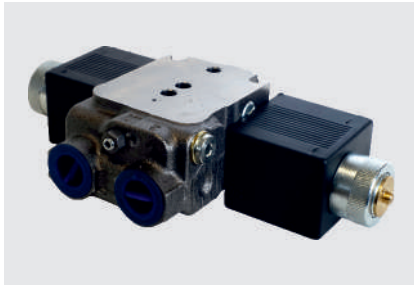

Main features

Max pressure	250 bar
Max pressure on T port	50 bar
Max flow	up to 40 l/min
Weight	1,6 Kg
Internal leakage	0,04 l/min at 100bar
Coil insulation	Class H
Electric connection	DIN 43650-A / ISO 4400
Protection class	IP 65 / DIN 40050
Duty cycle	ED 100%
Voltage required	+/- 10% nominal voltage
Manual Override	push
Standards	EN50081-1 / EN50082-2 (89/336 CEE electromagnetic comp.) 73/23/CEE / 96/68/CEE (low voltage)

Code

- SPD02** — Stackable directional proportional valve
- E2** — Spool configuration see table below
- 0D** — Spool throttling type see table Flow vs Current below
- TP** — Top Port
- LS** — Load Sensing
- 24DC** — Supply voltage 12VDC or 24VDC

Spool



Hydraulic scheme

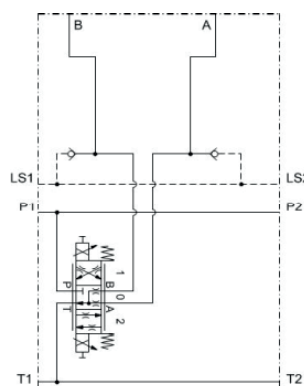

Flow Vs Current @ 18bar

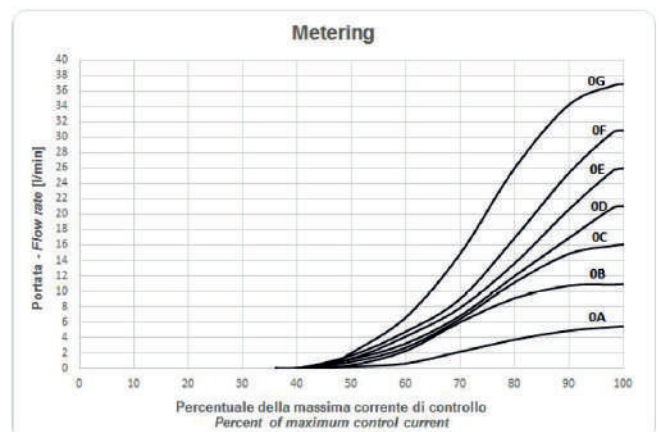

For valves mounting blocks see Power Pack Compact catalogue.

STACKABLE PROPORTIONAL ELECTROVALVE with LS & PRESSURE COMPENSATOR

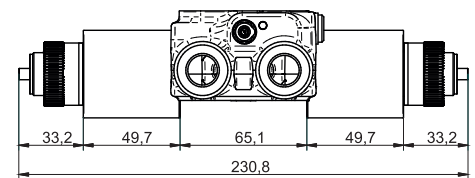
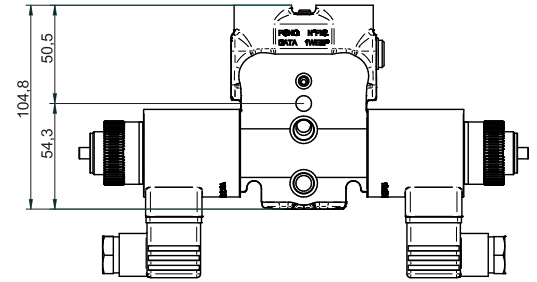
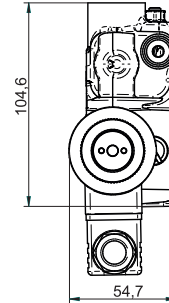
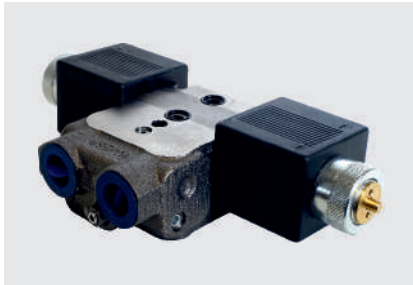

Main features

Max pressure	250 bar
Max pressure on T port	50 bar
Max flow	up to 32 l/min
Weight	1,6 Kg
Internal leakage	0,04 l/min at 100bar
Coil insulation	Class H
Electric connection	DIN 43650-A / ISO 4400
Protection class	IP 65 / DIN 40050
Duty cycle	ED 100%
Voltage required	+/- 10% nominal voltage
Manual Override	push
Standards	EN50081-1 / EN50082-2 (89/336 CEE electromagnetic comp.) 73/23/CEE / 96/68/CEE (low voltage)

Code

- SPD02** — Stackable directional proportional valve
- E2** — Spool configuration see table below
- 0D** — Spool throttling type see table Flow vs Current below
- TP** — Top Port
- LSCP** — Load Sensing & Pressure Compensator
- 24DC** — Supply voltage 12VDC or 24VDC

Spool



Hydraulic scheme

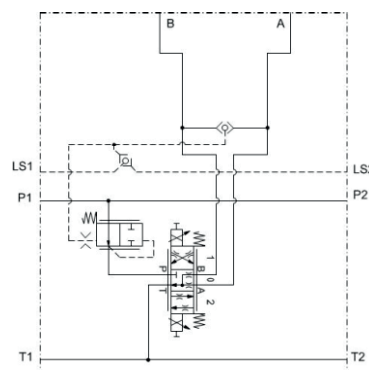

Flow Vs Current @ 10bar

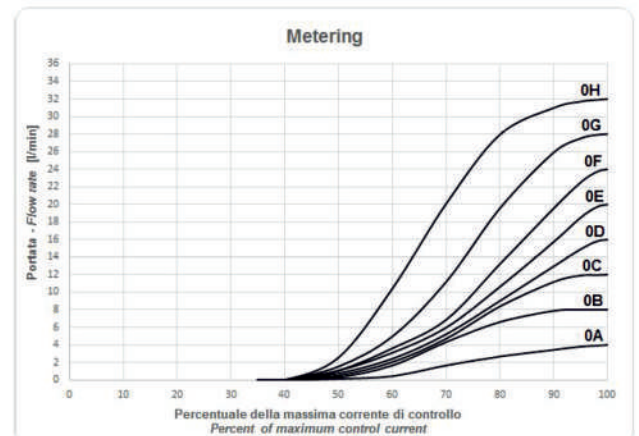

For valves mounting blocks see Power Pack Compact catalogue.

SECTION E



CETOP3 (NG6) PROPORTIONAL DIRECTIONAL VALVE

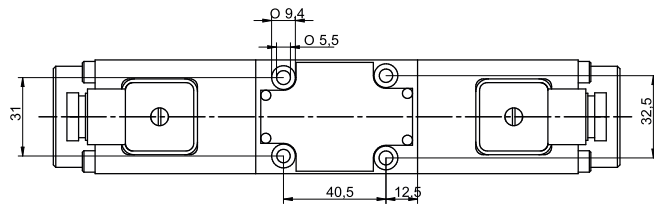
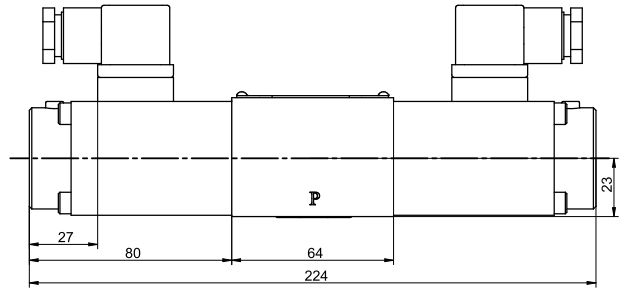

Main features

Max pressure	315 bar
Max pressure on T port	160 bar
Max flow	up to 10 l/min
Weight 2 solenoids	2,5 Kg
Weight 1 solenoid	1,8 Kg
Coil insulation	Class H
Electric connection	DIN 43650-A / ISO 4400
Protection class	IP 65 / DIN 40050
Duty cycle	ED 100%
Voltage required	+/- 10% nominal voltage
Manual Override	push
Standards	EN50081-1 / EN50082-2 (89/336 CEE electromagnetic comp.) 73/23/CEE / 96/68/CEE (low voltage)

Code

- SPD03** — CETOP3 (NG6) proportional valve
- E2** — Spool configuration: see table below
- 10** — Flow [lpm]
- — Options: - = std

Spool

Code	
E2	
B2	

Flow vs current

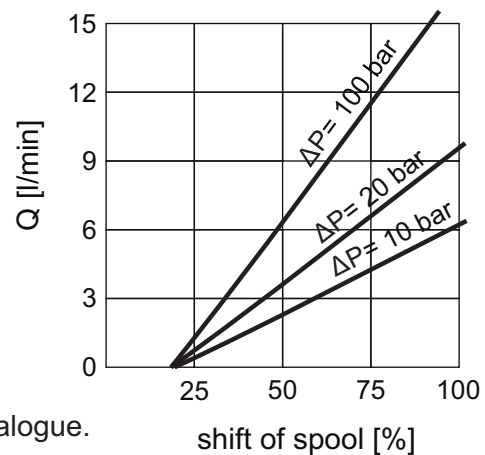

For valves mounting blocks see Power Pack Compact catalogue.

SECTION E



STACKABLE MODULAR DIRECTIONAL SOLENOID VALVES WITH REAR PORTS

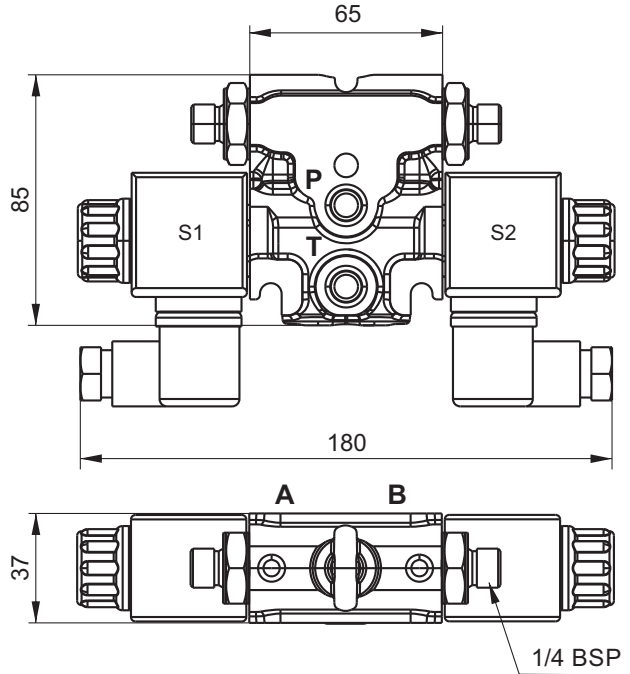
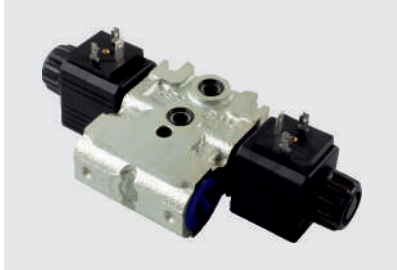

Options

Description	Spare part code
Closure plate, to be used as the last element	SD02TOP
Kit 3 tie rods + nut M8 8.8 (x = number of element)	SD020x

Main features

Max pressure	250 bar
Max pressure on T port	50 bar
Max flow	50 l/min
Weight	1,37 Kg (1 solenoid) 1,67 Kg (2 solenoid)
Internal leakage	0,02±0,06 l/min at 100bar, 21 cSt
Fixing bolts	3 TCEI M8 tie-rods 15 Nm torque. 8.8 class steel or above
Coil insulation	Class H
Electric connection	DIN 43650-A / ISO 4400
Protection class	IP 65 / DIN 40050
Duty cycle	ED 100%
Voltage required	+/- 10% nominal voltage
Manual Override	included as standard
Standards	EN50081-1 / EN50082-2 (89/336 CEE electromagnetic comp.) 73/23/CEE / 96/68/CEE (low voltage)
Fluid temperature	-20°C +80°C

Spare part code

SD02	Stackable modular directional solenoid valve
E2	Spool configuration: see below table
RP	Option: - = free outputs RP = outputs with piloted check valves (only spool E2 and C2)
24DC	Supply voltage: see coils table section G

Spool

Double solenoid

A2	
B2	
C2	
E2	

Single solenoid

A11C	 transitory
-------------	----------------

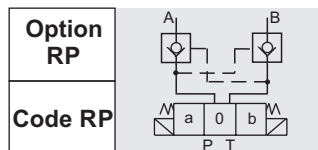

Limits of use

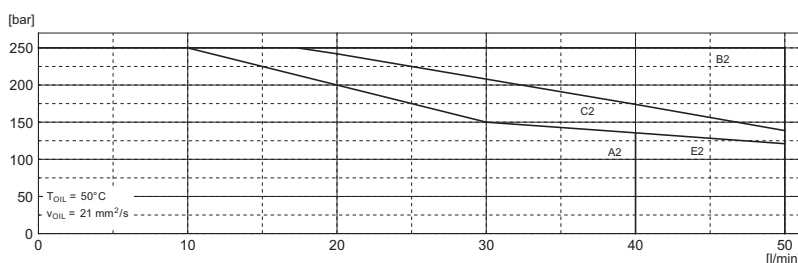

SECTION E



STACKABLE SOLENOID VALVES WITH 3/4-16UNF CAVITY FOR ADDITIONAL VALVES

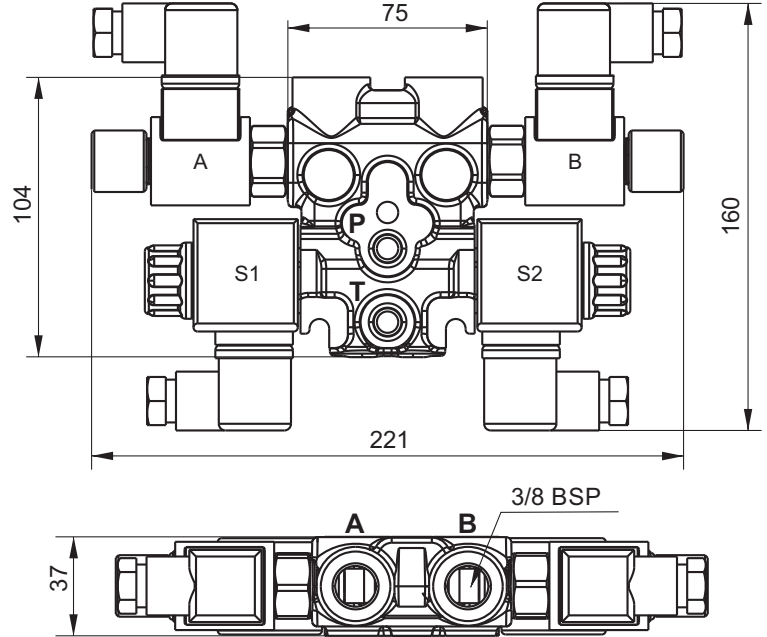

Options

Description	Spare part code
Closure plate, to be used as the last element	SD02TOP
Kit 3 tie rods + nut M8 8.8 (x = number of element)	SD020x

Main features

Max pressure	250 bar
Max pressure on T port	50 bar
Max flow	50 l/min
Weight	2,08 Kg (1 solenoid) 2,38 Kg (2 solenoid)
Internal leakage	0,02±0,06 l/min at 100bar, 21 cSt
Fixing bolts	3 x M8 tie-rods 15 Nm torque. 8.8 class steel or above
Coil insulation	Class H
Electric connection	DIN 43650-A / ISO 4400
Protection class	IP 65 / DIN 40050
Duty cycle	ED 100%
Voltage required	+/- 10% nominal voltage
Manual Override	included as standard
Standards	EN50081-1 / EN50082-2 (89/336 CEE electromagnetic comp.) 73/23/CEE / 96/68/CEE (low voltage)
Fluid temperature	-20°C +80°C

Note: For limits of use see diagram page G020

Spare part code

- SD02** — Stackable modular directional solenoid valve + cavity 3/4-16UNF for additional valves
- E2** — Spool configuration: see table below
- TP** — Version: TP = parallel ports with 3/4-16 UNF cavity
- 24DC** — Supply voltage: see coils table section G
- AR24DC** — Cavity A: X = open cavity
L = closed plug
ARxx = valve 2/2 NC (xx = voltage)
S = check flow bidirectional valve
- AR24DC** — Cavity B: X = open cavity
L = closed plug
ARxx = valve 2/2 NC (xx = voltage)
S = bidirectional flow control valve

Spool

Double solenoid

A2	
B2	
C2	
E2	

Single solenoid

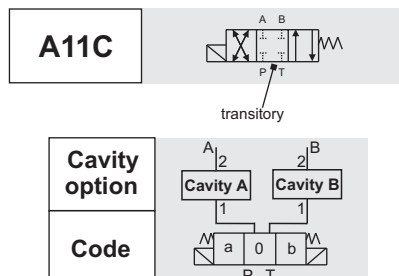

SECTION E



NG3 MICRO DIRECTIONAL SOLENOID VALVES

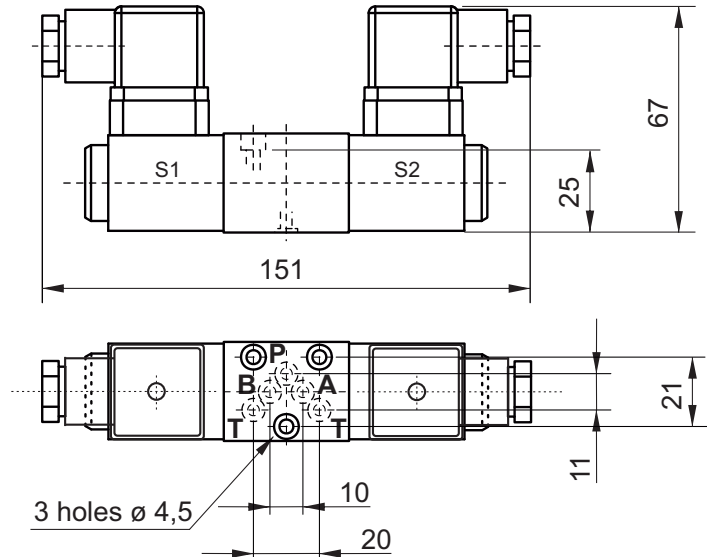
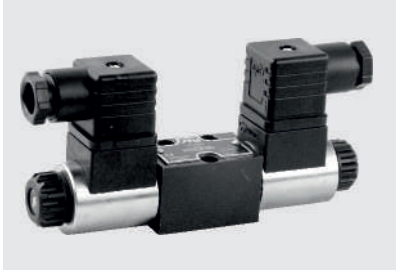

Main features

Max pressure	315 bar
Max pressure on T port	100 bar
Max flow	15 l/min
Weight	0,7 kg (2 solenoid) 0,55 kg (1 solenoid)
Internal leakage	< 0,01 l/min at 200bar
Fixing bolts	3 TCEI M4x35 bolts 2,8 Nm torque. 10,9 class steel or above
Coil insulation	Class H
Electric connection	DIN 43650-A / ISO 4400
Protection class	IP 65 / DIN 40050
Duty cycle	ED 100%
Voltage required	+/- 10% nominal voltage
Manual Override	included as standard
Standards	EN50081-1 / EN50082-2 (89/336 CEE electromagnetic comp.) 73/23/CEE / 96/68/CEE (low voltage)

Spare part code

SD00	NG3 micro directional solenoid valve
A2	Spool configuration: see table below
24DC	Supply voltage: see coils table section G
-	Options: - = std

Spool

Double solenoid

A2	
B2	
C2	
E2	

Single solenoid

A11C	
-------------	--



Notes: To use these valves, it is necessary to insert a filter of at least 15 microns in the hydraulic circuit.

SECTION E



NG6 (CETOP 3) DIRECTIONAL SOLENOID VALVES

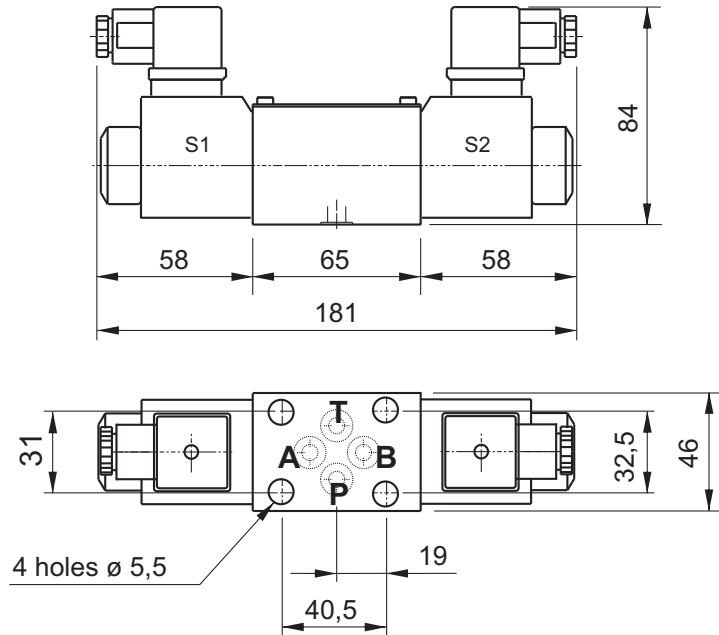

Main features

Max pressure	280 bar
Max pressure on T port	210 bar static, 180 bar dynamic
Max flow	40 l/min
Weight	1,43 kg (2 solenoid) 1,16 kg (1 solenoid)
Internal leakage	0,04 l/min at 200bar
Fixing bolts	4 M5x30 bolts. 5Nm torque 10,9 class steel or above
Coil insulation	Class H
Electric connection	DIN 43650-A / ISO 4400
Protection class	IP 65 / DIN 40050
Duty cycle	ED 100%
Voltage required	+/- 10% nominal voltage
Manual Override	included as standard
Standards	EN50081-1 / EN50082-2 (89/336 CEE electromagnetic comp.) 73/23/CEE / 96/68/CEE (low voltage)

Spare part code

SD03	Cetop 3 directional solenoid valve
A2	Spool configuration: see table below
24DC	Supply voltage: see coils table section G
-	Options: - = std

Spool

Double solenoid

A2	
B2	
C2	
E2	



Single solenoid

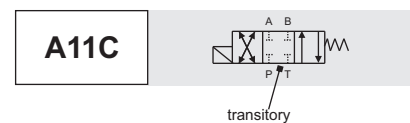



NOTES

A series of horizontal dotted lines for taking notes, spanning the width of the page.

"This project has received funding from the European Union's Horizon 2020 research and innovation programme under grant agreement N° 779020"

IMPORTANT NOTE. All information contained in this catalogue is subject to change without notice. Images are not to scale. Hydronit Srl does not make any representations or warranties (implied or otherwise) regarding the accuracy and completeness of this document and shall in no event be liable for any loss of profit or any commercial damage, including but not limited to special, incidental, consequential or other damage. The terms and conditions of sale, downloadable from www.hydronit.com, including limitations of our liability, are applied to all products and services sold.

XDRAULICS

a brand of:

Hydronit

via Pastrengo 62
20814 Varedo (MB), Italy

☎: +39 0362 1841 210

+39 0232 0625 145

☎: +39 0362 1841 214

✉: salesx@xdraulics.com

www.xdraulics.com

www.hydronit.com

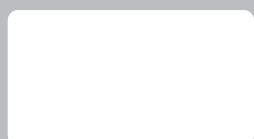

Hydronit communicates with paper from certified sources



© Hydronit Srl - All rights reserved
Printed in Italy

SPU 2020-01/EN